

RADIAL PISTON PUMP

RKP

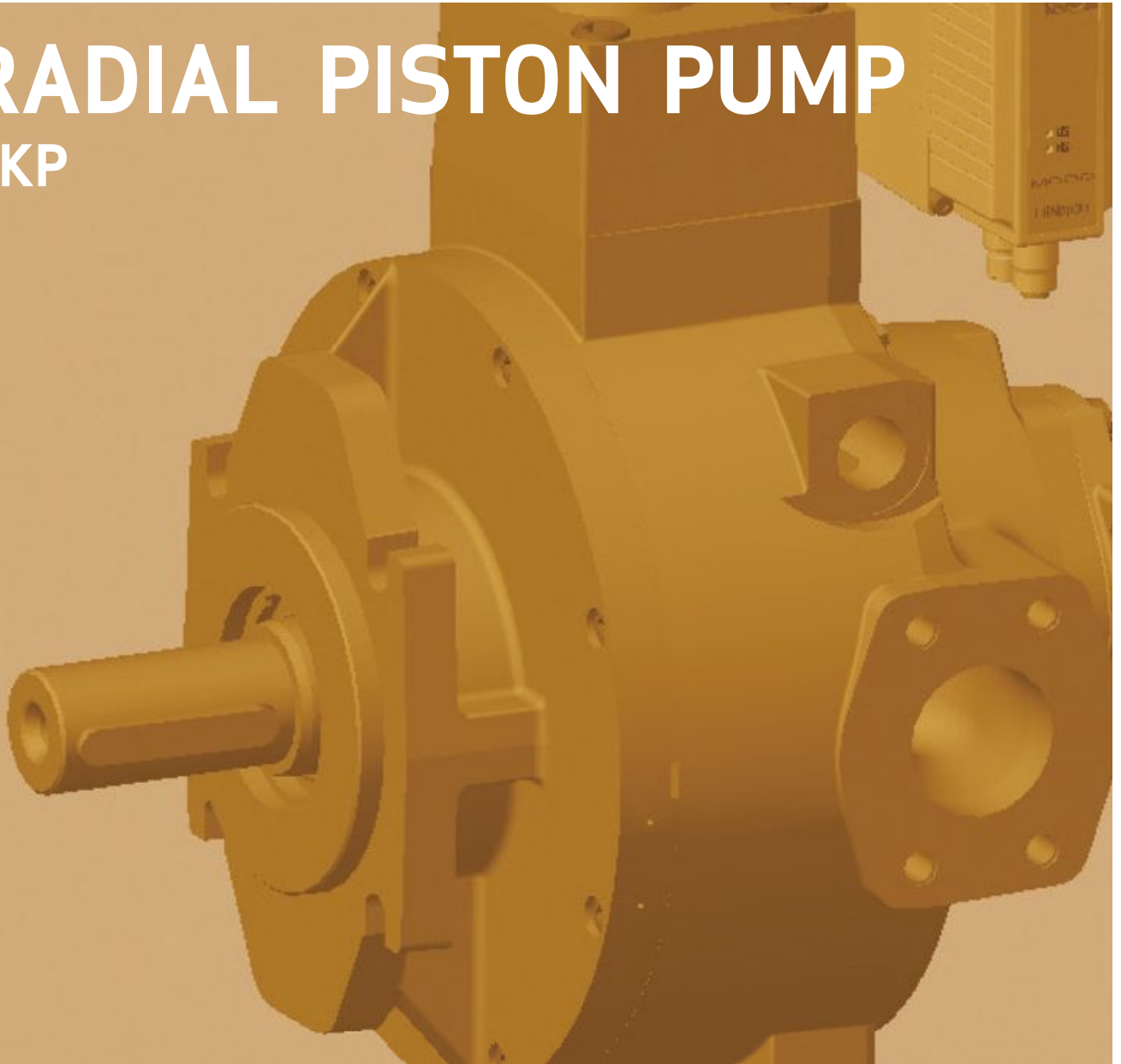

Rev. F, May 2014

MODULAR DESIGN FOR SUPERIOR PERFORMANCE
QUIET AND ROBUST

Whenever the highest levels of motion control performance and design flexibility are required, you'll find Moog expertise at work. Through collaboration, creativity and world-class technological solutions, we help you overcome your toughest engineering obstacles. Enhance your machine's performance. And help take your thinking further than you ever thought possible.

INTRODUCTION..... 2

 General information..... 3

 Product description 4

 Product overview 5

TECHNICAL DATA 7

 Performance curves..... 7

 Compensator options 10

 Multiple arrangements 11

 Technical information..... 16

 Appendix A - Compensator options..... 17

 Appendix B - Technical drawings RKP 19 to 100..... 30

 Appendix C - Technical drawings RKP 140 and 250 .. 53

 Appendix D - External gear pump 70

BACKGROUND 73

 About Moog 73

 Conversion table..... 75

ORDERING INFORMATION 76

 Model code..... 76

CONTACT 80



This catalog is for users with technical knowledge. To ensure all necessary characteristics for function and safety of the system, the user has to check the suitability of the products described herein. The products described in this document are subject to change without notice. In case of doubt, please contact Moog.

Moog is a registered trademark of Moog Inc. and its subsidiaries. All trademarks as indicated herein are the property of Moog Inc. and its subsidiaries. For the full disclaimer refer to www.moog.com/literature/disclaimers.

For the most current information, visit www.moog.com/industrial or contact your local Moog office.

GENERAL INFORMATION

Outstanding Motion Control Solutions

For over 50 years, we have been a leader in motion control technology, specialising in the manufacture and application of high performance products. Today, we incorporate the latest motion control technology into our products and offer innovative ideas that can help our customers achieve new levels of machine performance.

Proven Pump Technology

The Radial Piston Pump product line (also known as RKP), is a range of high performance variable displacement pumps intended for use in industrial applications. Based on a proven concept, the RKP's robust and contamination resistant design results in long life and a high degree of reliability.

Its rapid response time and high volumetric efficiency have led to it being the first choice for many machines with demanding flow and pressure control needs.

We produce a wide range of radial piston pumps of different sizes, single and multiple arrangements, with various forms of control (mechanical, hydro-mechanical, electro-hydraulic, digital and analog) in order to provide maximum flexibility to machine builders.

Applications

Thanks to the flexible, high performance design, the RKP is the ideal solution for all types of industrial applications. The RKP is already used in machines for injection molding, die casting, forming equipment such as presses and rolls, as well as in general hydraulic applications. In the field of plastic and metal processing, the RKP is used on equipment to produce plastic and metal parts, for the packaging and automotive industries. The RKP is also used in test equipment, construction, rubber processing, and the mining industry.

The RKP is particularly well suited to applications where power, low noise and robust design, in combination with precision and speed are needed.

Low-Noise and Rugged Design

With a number of innovative design features we have been able to reduce both the primary and the secondary noise level from the RKP. For sizes 63 and 80 cm³/rev, the number of pistons have been increased from 7 to 9, reducing the working piston diameter leading to lower dynamic transverse forces acting on the housing.

As a result the flow and pressure pulsations on the high pressure side have been reduced, enabling the RKP to help machine manufacturers comply with EU directive "2003/10/EC" on noise emissions.

The design minimizes wear on the internal pump components, even under the most demanding operating conditions, thereby extending the service life of the machine.

RKP-II and RKP

During the introduction of the new pump design we have used the term "RKP-II" for clarity. By now only a very small portion of the deliveries remain on the old design, used mainly for replacements in existing equipment. The actual configuration is unequivocal in the model number. Therefore we have discontinued the use of the term "RKP-II" in our publications. In this catalog we use only the term "RKP" when we refer to the radial piston pump.

Digital or Analog Control

The control technology of the RKP pump has been significantly improved with a new integral closed-loop proportional valve, with digital on-board electronics for flow and pressure regulation, tuning, and diagnostics.

The RKP can be digitally controlled via a CANopen or EtherCAT interface or controlled by analog command signals.

Details of the significant benefits available from running the RKP in either fieldbus or analog modes are outlined in a separate catalog for the RKP-D pump.

PRODUCT DESCRIPTION

Quiet and Robust

Design

The RKP pumps benefit from low noise levels. Sizes 32 to 250 are fitted with a sliding stroke ring. The big suction port supports the use of wide suction lines. The control port of the compensators is built in G 1/4".

RKP stands for reliability, low noise, and durability and this is underlined by its extended warranty. Under the conditions described on page 5, warranty for mineral oil is covered for 10,000 operating hours or 24 months.

Further Advantages of the Moog Radial Piston Pump RKP are:

- Fast response
- Compact modular design enabling the pump selection to match the application
- Good suction characteristics
- Low pressure ripple

The following RKP features are available:

- Medium pressure series (280 bar (4,000 psi)) and high pressure series (350 bar (5,000 psi)) for mineral oil
- Large selection of compensators including mechanical, hydraulic and electro-hydraulic (analog or digital with CANopen or EtherCAT)
- Mechanical flow limitation
- Multiple pumps by tandem mounting
- Various drive flanges
- Suitable for most hydraulic oils such as mineral oil, transmission oil, biodegradable oil and synthetic esters (HFD)
- Suitable pump versions are also available for special fluids such as oil in water emulsions, (HFA and HFB), water-glycol (HFC), lubricating oils and cutting emulsions. See the catalog Radial Piston Pump RKP for Low-Flammability Fluids for details of these pumps.

Mode of Operation

The shaft (5) transfers the drive torque to the star-shaped cylinder block (3), free of any transverse forces via a crossdisc coupling (4). The cylinder block is supported on the control journal (1). The radial pistons (9) in the cylinder block run against the stroke ring (7) through hydrostatically balanced slipper pads (8). Piston and slipper pads are joined by ball and socket joints which is locked by a ring. The slipper pads are guided in the stroke ring by two retaining rings (2) and, when running, are held against the stroke ring by centrifugal force and oil pressure. As the cylinder block rotates, the pistons perform a reciprocating motion due to the eccentric positioning of the stroke ring, the piston stroke being twice the eccentricity. The eccentric position of the stroke ring is controlled by two diametrically opposed control pistons (6, 10) and the compensator (11). The oil flow to and from the pump passes through the pump ports and into and out of the pistons through the porting in the control journal. The rolling bearing, supporting the drive shaft, is only subjected to external forces. The compensator setting limits the system pressure and adjusts the pump flow between zero and full flow to maintain the set pressure. At the RKP-D the position of the stroke ring is detected by an LVDT (12) and high dynamically controlled by a servo pilot valve (13).

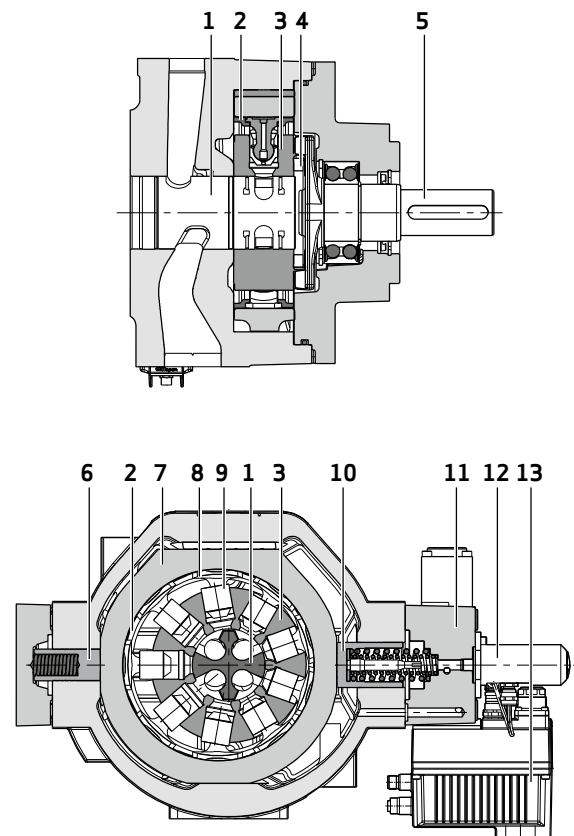

PRODUCT OVERVIEW

Displacement [cm ³ /rev]	19	32	45	63	80	100	140	250
Type of construction	Pump for open circuit with various control devices							
Type of mounting	End mounting, centering and hole-circle diameter to ISO 3019-2 (metric) Mounting flange to ISO 3019-1 (inch), Mounting flange to ISO 3019-2 (metric)							
Mounting position	Optional							
Weight [kg (lb)]	22 (49)	33 (73)	33 (73)	71 (157)	71 (157)	71 (157)	105 (232)	236 (521)
Mass moment of inertia [kg cm² (10⁻⁴ lbf in s²)]	17.7 (157)	61.0 (540)	61.0 (540)	186.3 (1,649)	186.3 (1,649)	186.3 (1,649)	380.0 (3,363)	1,555 (13,671)
Line connections according to ISO 6162:								
Medium pressure series 280 bar (4,000 psi)								
Pressure port	SAE 3/4"	SAE 1"	SAE 1"	SAE 1 1/4"	SAE 1 1/4"	SAE 1 1/4"	SAE 1 1/2"	
Suction port	3,000 psi SAE 3/4"	3,000 psi SAE 1 1/2"	3,000 psi SAE 1 1/2"	3,000 psi SAE 2"	3,000 psi SAE 2"	3,000 psi SAE 2"	6,000 psi SAE 2"	6,000 psi SAE 2 1/2"
High pressure series 350 bar (5,000 psi)								
Pressure port	SAE 3/4"	SAE 1"		SAE 1 1/4"	SAE 1 1/4"			SAE 1 1/2"
Suction port	6,000 psi SAE 3/4"	6,000 psi SAE 1 1/2"		6,000 psi SAE 2"	6,000 psi SAE 2"			6,000 psi SAE 3"
Recommended pipe OD for drain lines (lightweight version) [mm (in)]	15 (5/8")	18 (3/4")	18 (3/4")	22 (7/8")	22 (7/8")	22 (7/8")	22 (7/8")	35 (1 1/4")
Drain	The drain line is to be routed so that the pump housing is always full of the pumped fluid. The pressure at the drain port must not exceed 1 bar (15 psi) gauge pressure (2 bar (29 psi) absolute). The drain line to be piped directly to tank without filter, cooler, check valve etc. and must terminate below the minimum fluid level.							
Type of drive	Direct drive with coupling (please inquire from your Moog contact for other types)							
Ambient temperature range [°C (°F)]	-15 to +60 (+5 to +140)							
Maximum speed at inlet pressure 0.8 bar (12 psi) abs. [min⁻¹] 1 bar (15 psi) abs. [min⁻¹]	2,700 2,800	2,500 ³⁾ 2,600 ³⁾	2,000 ³⁾ 2,100 ³⁾	2,400 ³⁾ 2,500 ³⁾	2,000 ³⁾ 2,050 ³⁾	1,800 1,850	1,800 1,900	1,800 1,850
Maximum speed for quiet running [min⁻¹]	1,800	1,800	1,800	1,800	1,800	1,800	1,800	1,800
Minimum inlet pressure suction connection [bar (psi)]	0.8 (12) absolute							
Maximum housing pressure [bar (psi)]	2 (29) (1 (15) gauge pressure)							

For special fluids e.g., HFA, HFC and emulsions the above pressure, viscosity and filtration parameters may be changed. See the relevant special fluids catalog for details.

¹⁾ Maximum pressure to ISO 5598

²⁾ Dirt particles retention rate > 20 µm is 1: 75, i.e. 98,67%

³⁾ Maximum speed increase on request

1,000 psi = 70 bar

PRODUCT OVERVIEW

Displacement [cm ³ /rev]	19	32	45	63	80	100	140	250
Pressures [bar (psi)]								
Medium pressure series								
Continuous pressure	280 (4,000)	280 (4,000)	280 (4,000)	280 (4,000)	280 (4,000)	280 (4,000)	280 (4,000)	
Maximum pressure ¹⁾	315 (4,500)	315 (4,500)	315 (4,500)	315 (4,500)	315 (4,500)	315 (4,500)	315 (4,500)	
Pressure peak	350 (5,000)	350 (5,000)	350 (5,000)	350 (5,000)	350 (5,000)	350 (5,000)	350 (5,000)	
High pressure series								
Continuous pressure	350 (5,000)	350 (5,000)		350 (5,000)	350 (5,000)			350 (5,000)
Maximum pressure ¹⁾	385 (5,500)	385 (5,500)		385 (5,500)	385 (5,500)			385 (5,500)
Pressure peak	420 (6,000)	420 (6,000)		420 (6,000)	420 (6,000)			420 (6,000)
Hydraulic fluid	Mineral oil according to DIN 51524							
Hydraulic fluid temperature range [°C (°F)]	-15 to +80 (+5 to +176)							
Viscosity mm²/s (cSt)	Allowable viscosity operational range 12 to 100 Recommended viscosity 16 to 46; hydraulic fluid viscosity class VG 46 or VG 32 according to ISO 3448 Maximum viscosity 500 during start-up with electric motor at 1,800 min ⁻¹							
Filtering	NAS 1638, class 9; ISO 4406, class 20/18/15; obtained with filter fineness of $\beta_{20} = 75$ ²⁾ NAS 1638, class 7; ISO 4406, class 18/16/13; with electro-hydraulic control (RKP-D)							

For special fluids e.g., HFA, HFC and emulsions the above pressure, viscosity and filtration parameters may be changed. See the relevant special fluids catalog for details.

¹⁾ Maximum pressure to ISO 5598

²⁾ Dirt particles retention rate > 20 μm is 1: 75, i.e. 98,67%

³⁾ Maximum speed increase on request

1,000 psi = 70 bar

PERFORMANCE CURVES

Adjustment range

Caution: The rotation of the pump cannot be changed

Clockwise Rotation

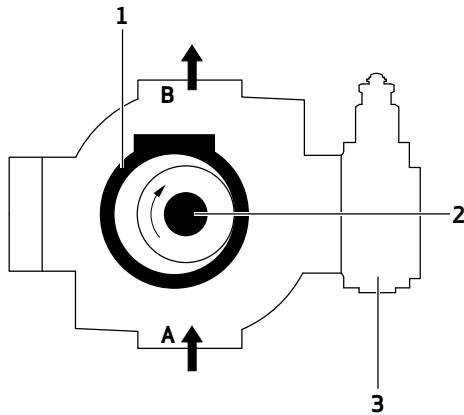

- 1 Stroke ring
- 2 Control journal
- 3 Compensator

Counterclockwise Rotation

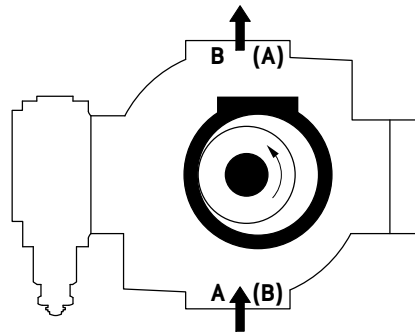

- Suction port A
- Suction port B

Power Consumption P

At maximum flow
 Hydraulic fluid: Mineral oil
 Viscosity $\nu = 35 \text{ mm}^2/\text{s}$ (cSt)
 Temperature $T = +50 \text{ }^\circ\text{C}$ (+122 $^\circ\text{F}$)

Note: For RKP 19

Suction port (B)
 Pressure port (A)

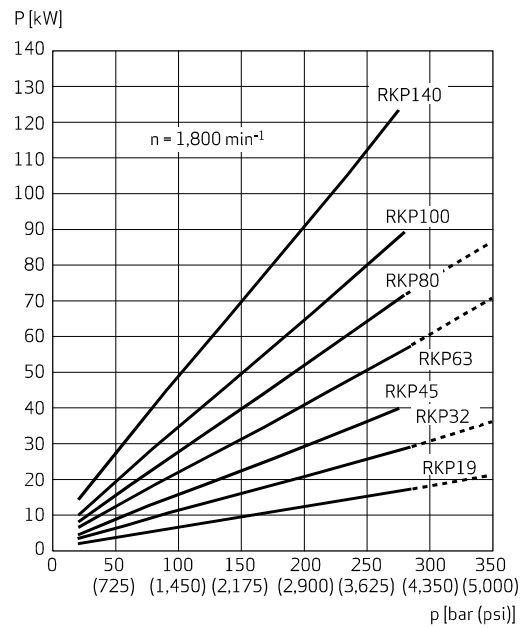
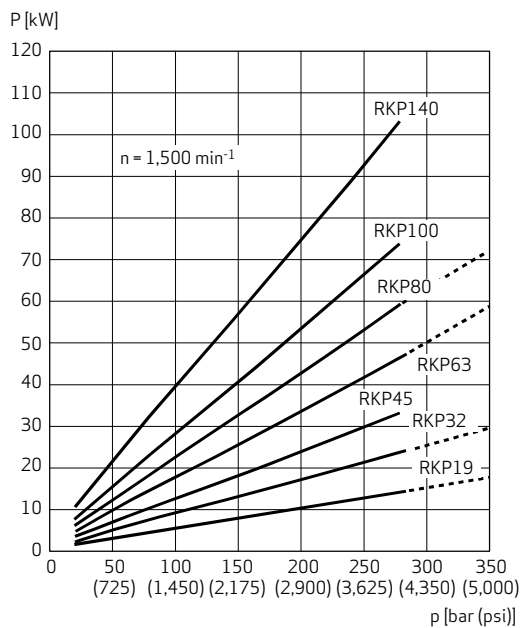

———— Standard version
 High-pressure version

PERFORMANCE CURVES

Noise Diagram

$n = 1,500 \text{ min}^{-1}$ at Q_{maximum}

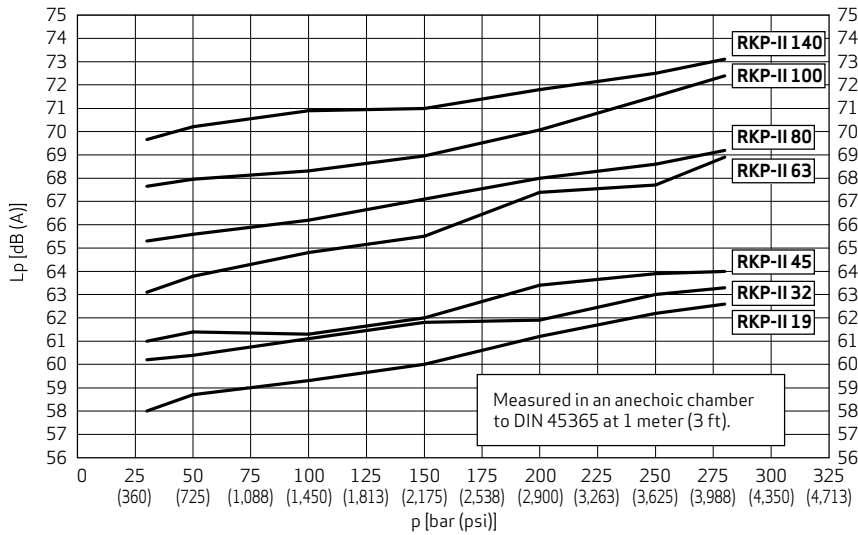

Noise emission values with combined pressure/flow compensator. These are average values over the operating range.

Performance Curves of Drive Power and Displacement

Response time $V_{\text{maximum}} \rightarrow V_{\text{minimum}}$: 20 to 50 ms (approx. value)

Response time $V_{\text{minimum}} \rightarrow V_{\text{maximum}}$: 50 to 100 ms

from 70 bar (1,015 psi) pressure setting (approx. value)

$n = 1,500 \text{ min}^{-1}$; $v = 35 \text{ mm}^2/\text{s}$ (cSt); $T = +50 \text{ }^\circ\text{C}$ (+122 $^\circ\text{F}$)

V = 19 cm³/rev

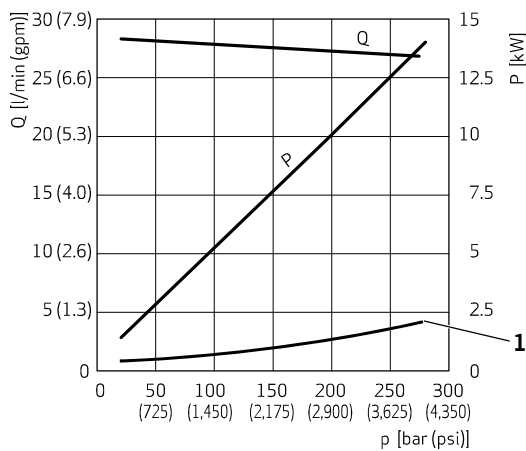

V = 32 cm³/rev

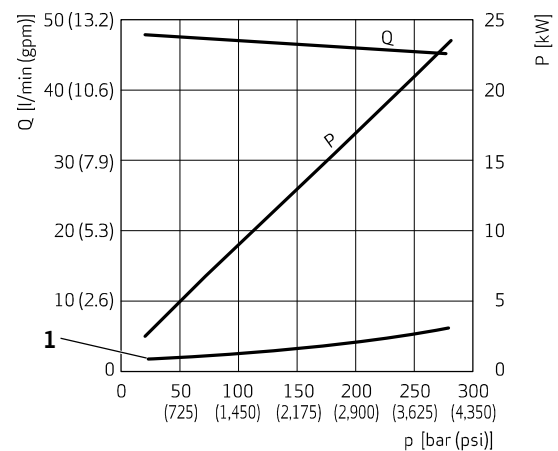

1 P at zero stroke

PERFORMANCE CURVES

V = 45 cm³/rev

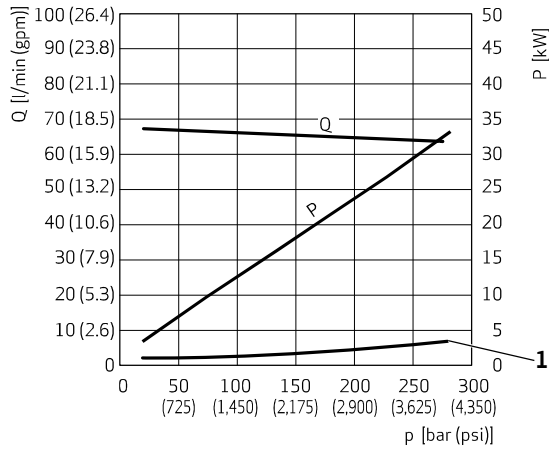

V = 63 cm³/rev

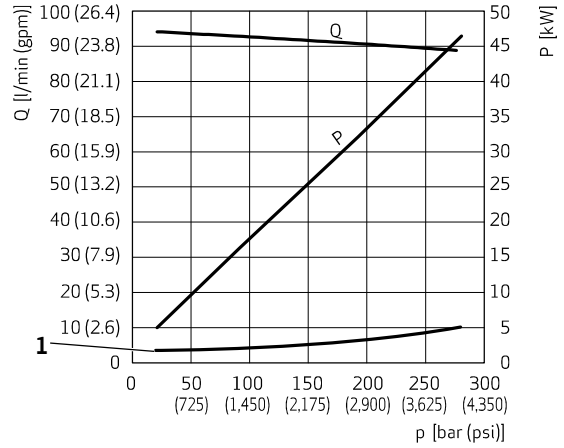

V = 80 cm³/rev

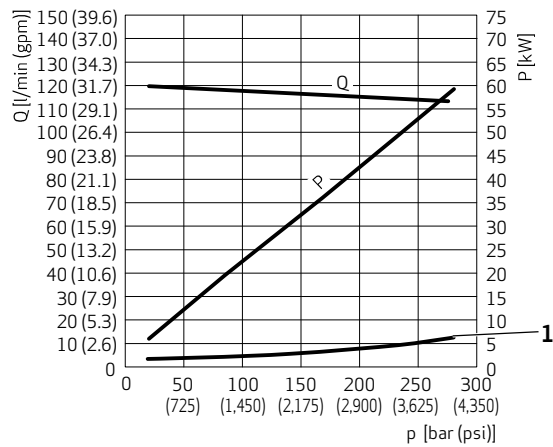

V = 100 cm³/rev

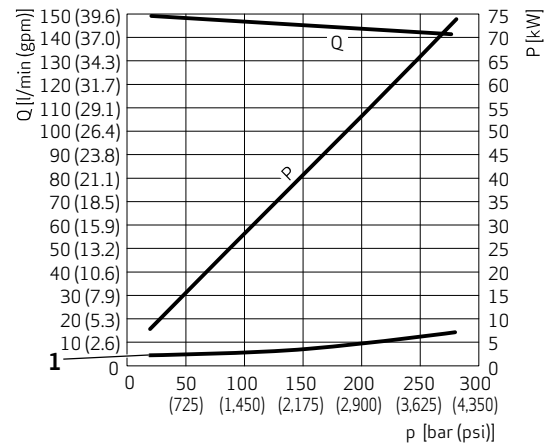

1 P at zero stroke

V = 140 cm³/rev

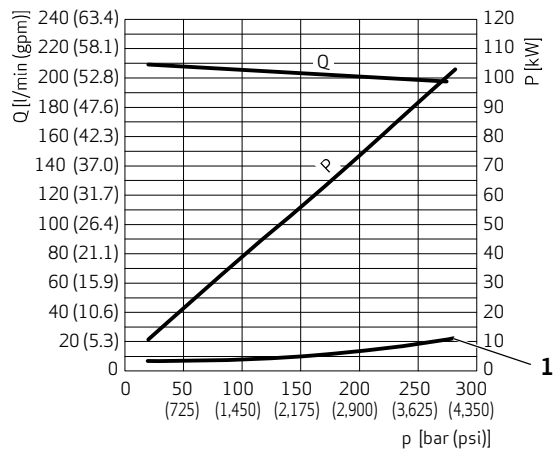

COMPENSATOR OPTIONS

RKP enables a variety of compensator options to be used thereby ensuring maximum flexibility.

The following options are described in more detail in appendix A.

Compensator option, Model code	Description/characteristics/application
1. Adjustable pressure compensator, Type F	For constant pressure systems with a fixed pressure setting
2. Remote pressure compensator, Type H1	For constant or variable pressure systems with remote pressure
3. Pressure compensator with Mooring control, Type H2	For constant pressure systems with a variable pressure setting for mooring control
4. Combined pressure and flow compensator, Type J	For displacement systems with a variable flow and load sensing pressure control
5. Combined pressure and flow compensator with P-T control notch, Type R	As 4. with additional active reduction of pressure peaks in the event of dynamic control process
6. Mechanical stroke adjustment, Type B	For displacement systems with a fixed displacement that may be manually adjusted as needed
7. Servo control, Type C1	Adjustment of displacement using a hand lever or an actuator
8. Constant horse-power control (force comparison system), Typ S1	Automatic reduction of displacement in the event of an increasing load so that the capacity of the drive motor is not exceeded
9. Constant horsepower control with remote pressure and flow control, Type S2	As 8. but with additional adjustable maximum limit for pressure and flow
10. Electro-hydraulically adjustable compensator with digital on-board electronics, Type D	For displacement systems with variable flow and/or pressure limitation
11. Dual-displacement, Type N1	For use in both speed variable operation and displacement controlled systems with two displacements at constant speed

MULTIPLE ARRANGEMENTS

Additional pumps can be tandem mounted on the radial piston pump, so that all pump stages can be driven by the same shaft. Radial piston pumps (the same size or smaller than the first pump stage) can be mounted directly.

Other pumps may be added on using adapter flanges for SAE-A, SAE-B or SAE-C respectively. For the maximum permitted through-drive torque for driving add-on pumps, please refer to the table below.

Adding on RKP, SAE-A, SAE-B or SAE-C Adapters Permissible Through-Drive Torques

Pump stage 1	Pump stage 2					SAE-A	SAE-B	SAE-C
RKP	RKP							
Size (cm ³ /rev)	19	32 45	63 80 100	140	250			
19	90 Nm (797 lbf in)	–	–	–	–	90 Nm (797 lbf in)	–	–
32/45	185 Nm (1,637 lbf in)	185 Nm (1,637 lbf in)	–	–	–	110 Nm (974 lbf in)	185 Nm (1,637 lbf in)	–
63/80/100	400 Nm (3,540 lbf in)	400 Nm (3,540 lbf in)	400 Nm (3,540 lbf in)	620 Nm (5,487 lbf in) ¹⁾	–	110 Nm (974 lbf in)	280 Nm (2,478 lbf in)	400 Nm (3,540 lbf in)
140	400 Nm (3,540 lbf in)	400 Nm (3,540 lbf in)	620 Nm (5,487 lbf in)	620 Nm (5,487 lbf in)	–	110 Nm (974 lbf in)	280 Nm (2,478 lbf in)	620 Nm (5,487 lbf in)
250	400 Nm (3,540 lbf in)	400 Nm (3,540 lbf in)	400 Nm (3,540 lbf in)	620 Nm (5,487 lbf in)	1,470 Nm (13,009 lbf in)	110 Nm (974 lbf in)	280 Nm (2,478 lbf in)	1,300 Nm (11,505 lbf in)

¹⁾ Special flange on request

The through-drive torque required to drive add-on pumps is determined by reference to the following variables:

V [cm ³ /rev]	Displacement
p [bar]	Pressure
η _{hm} [%]	Hydro-mechanical efficiency
M [Nm]	Through-drive torque

Through-drive torque from pump stage 1 to 2:

$$M_1 = 1.59 \cdot \sum_{i=2}^n \frac{V_i \cdot p_i}{\eta_{hmi}}$$

Example

If we take the following pump combination RKP 63 + RKP 63 + RKP 32 + AZP 16 280 bar (4,000 psi), 210 bar (3,000 psi), 150 bar (2,176 psi), 50 bar (725 psi), the following considerations apply:

Design of 1st Through-Drive

The pressure and flow of the 1st pump stage are irrelevant to the torque transferred by the through-drive. This torque can be calculated using the above formula.

$$M_1 = 1.59 \cdot \left(\frac{V_2 \cdot p_2}{\eta_{hm2}} + \frac{V_3 \cdot p_3}{\eta_{hm3}} + \frac{V_4 \cdot p_4}{\eta_{hm4}} \right)$$

$$M_1 = 1.59 \cdot (63 \cdot 210/95 + 32 \cdot 150/93 + 16 \cdot 50/90) \text{ Nm}$$

$$M_1 = 318 \text{ Nm}$$

The value 318 Nm (2,814 lbf in) is below the threshold value of 400 Nm (3,540 lbf in) specified in the above table for mounting an RKP 63 on another RKP 63.

Design of 2nd Through-Drive Torque

$$M_2 = 1.59 \cdot \left(\frac{V_3 \cdot p_3}{\eta_{hm3}} + \frac{V_4 \cdot p_4}{\eta_{hm4}} \right)$$

$$M_2 = 1.59 \cdot (32 \cdot 150/93 + 16 \cdot 50/90) \text{ Nm}$$

$$M_2 = 96 \text{ Nm}$$

Likewise, the value 96 Nm (850 lbf in) lies below the relevant threshold value of 400 Nm (3,540 lbf in) for the through-drive from RKP 63 to an RKP 32.

Design of 3rd Through-Drive Torque

Similarly, a value of 14 Nm (124 lbf in) is obtained for the torque required to drive the add-on gear pump. Thus, the through-drives for this pump combination are permissible with the stated pressures.

MULTIPLE ARRANGEMENTS

Radial piston pump with heavy-duty through-drive and tandem mounted radial piston pump.

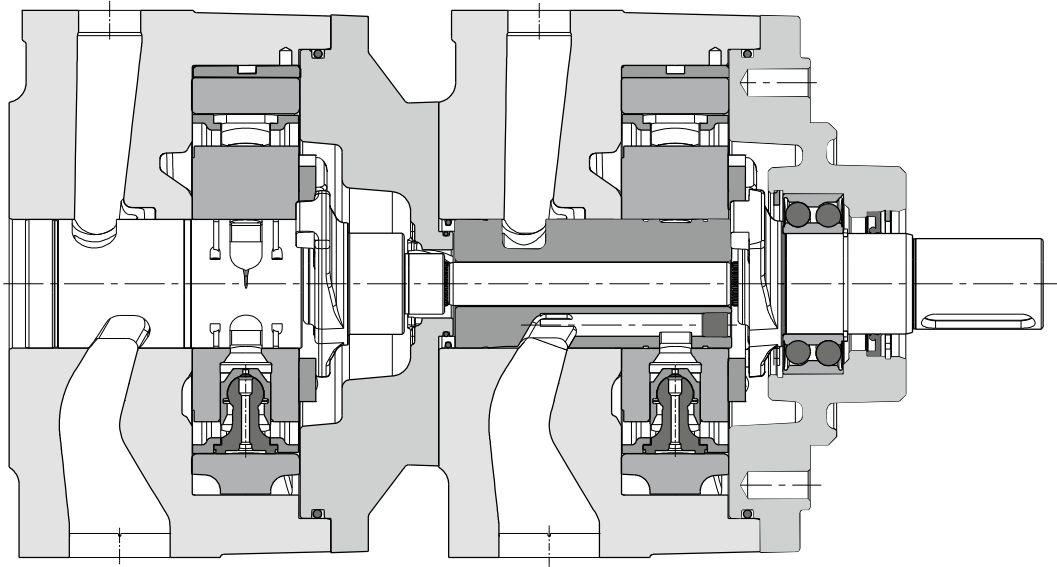

Radial piston pump with tandem mounted gear pump using SAE-A adapter. Technical data see page 70.

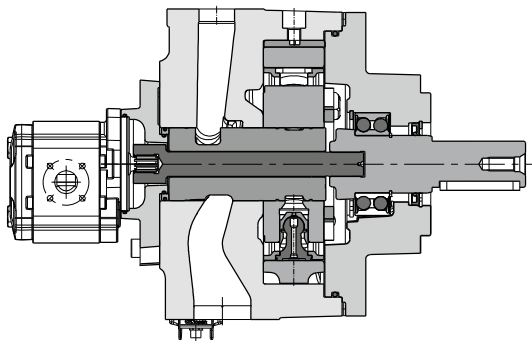

Radial piston pump with tandem mounted gear pump using SAE-B adapter. Technical data see page 72.

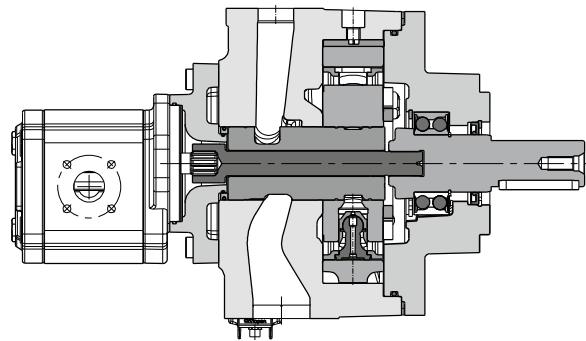

MULTIPLE ARRANGEMENTS

Adapter Flange for Fitting an External Pump Using Flange SAE-A According to ISO 3019-1 and 9-Tooth Shaft

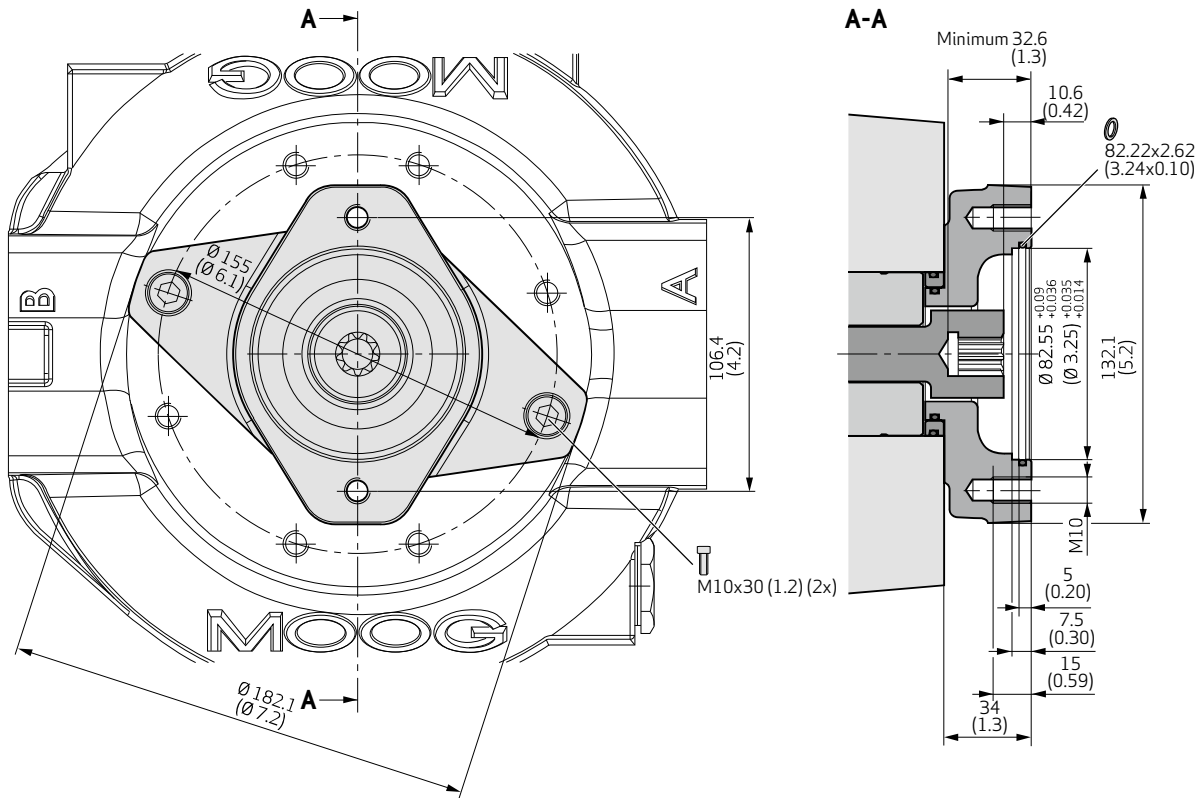

Flange code: 82-2

Shaft code: 16-4

Toothing to: ANSI B92.1 9T 16/32 DP Flat root side fit

Conditions for attachment: RKP with through-drive capability

Adaptor including through-drive shaft, seals (HNBR), intermediate ring for RKP 63 to 250 and 2 fastening screws.

RKP 19	CA41832-001
RKP 32/45	CA51553-001
RKP 63/80/100	CA64727-001
RKP 140	CA64728-001
RKP 250	CB65065-001

MULTIPLE ARRANGEMENTS

Adapter Flange for Fitting an External Pump Using Flange SAE-B According to ISO 3019-1 and 13-Tooth Shaft

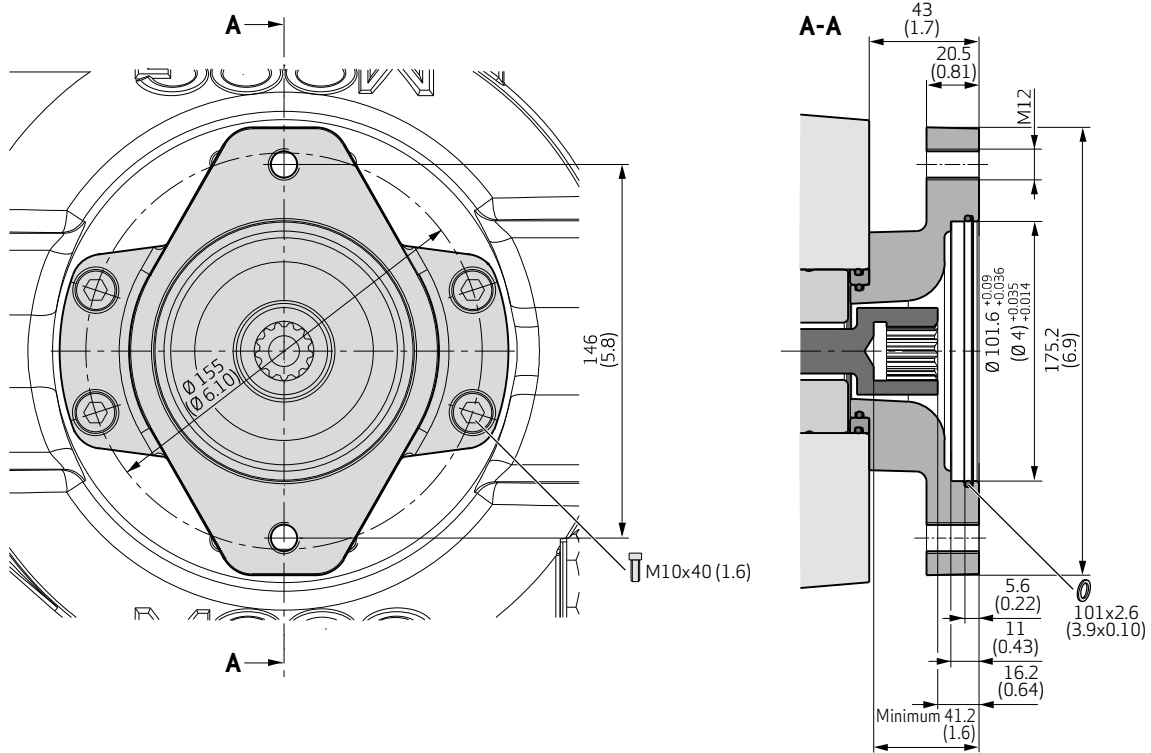

Flange code: 101-2

Shaft code: 22-4

Toothing to: ANSI B92.1 13T 16/32 DP Flat root side fit

Conditions for attachment: RKP with through-drive capability

Adaptor including through-drive shaft, seals (HNBR), intermediate ring for RKP 63 to 250 and 4 fastening screws.

RKP 32/45	CA36273-001
RKP 63/80/100	CA34793-001
RKP 140	CA50487-001
RKP 250	CB76956-001

MULTIPLE ARRANGEMENTS

Adapter Flange for Fitting an External Pump Using Flange SAE-C According to ISO 3019-1 and 14-Tooth Shaft

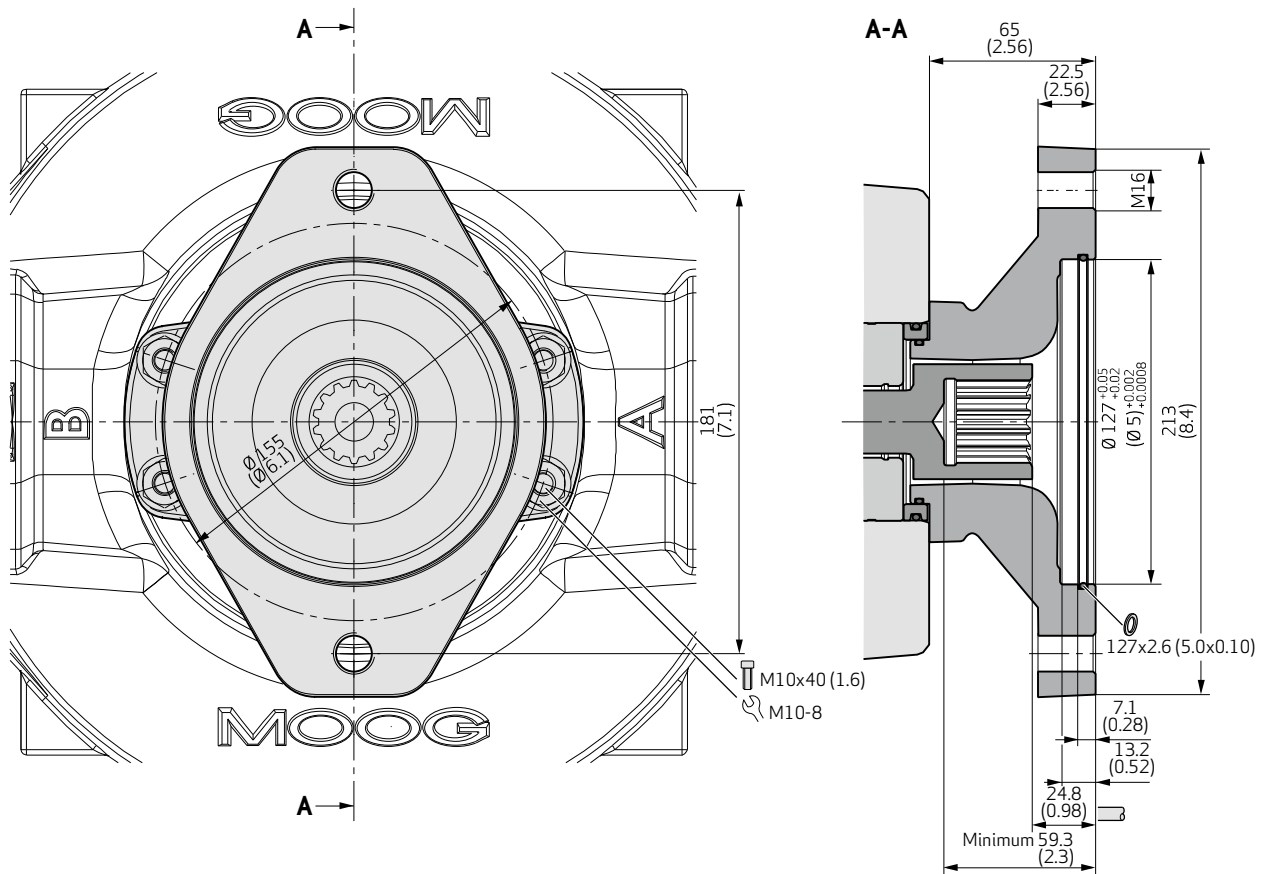

Flange code: 127-2

Shaft code: 32-4

Toothing to: ANSI B92.1 14T 12/24 DP Flat root side fit

Conditions for attachment: RKP with through-drive capability

Adaptor including through-drive shaft, seals (HNBR), intermediate ring for RKP 140 and 250 and 4 fastening screws.

RKP 63/80/100	CA64621-001
RKP 140	CA64622-001
RKP 250	CB76962-001

TECHNICAL INFORMATION

Important

The pump must be put into service by a trained hydraulic systems engineer.

Installation

The radial piston pump can be mounted in any position. The drive shaft must not be subject to radial or axial loads and should therefore be driven through a flexible coupling. The pump must be driven in the correct direction of rotation. All plugs on the pump should only be removed immediately before the pipes are connected and standard hydraulic cleanliness procedures to be used. The use of cold drawn seamless steel pipes in accordance with DIN 2391 is recommended.

Suction Line (A)

It is recommended that final piping connections to the pump are flexible hoses. The shortest possible suction line should be used with a diameter large enough to give a fluid velocity below 1.5 m/s (0.06 in/s). Sharp angles and screwed pipe joints should be avoided due to the danger of air ingress and excessive pressure drop therefore, pipe bends and/or hoses should be used. The minimum permissible inlet pressure must be maintained. If a suction filter (minimum 0.15 mm (0.01 in) mesh aperture) or an isolating valve is to be used, it must be installed below the fluid level.

Pressure Line (B)

Ensure the pressure pipework is securely clamped and the screws are correctly torque tightened.

Drain Line (L)

The upper drain port must be used for the drain line and the pipework is to be routed to ensure the housing is always full of fluid. The pipe should lead directly to the tank, separate from other return lines. For RKP250 port L1 must be used for drain line connection. The bearing cover of the pump must be assembled with port L1 in upper position. For description of port L2 see further information in chapter "Flushing the housing". It must terminate below the lowest fluid level and should be as far away from the suction take off as possible. Do not fit a filter, cooler or non-return valve in the drain line. The maximum recommended length for the drain line is 3 m (10 ft). The pressure at drain port is not to exceed 1 bar gauge (15 psi) (2 bars absolute (29 psi)). The recommended outside pipe diameters for drain lines (lightweight version) are:

RKP 19: 15 mm (5/8")
 RKP 32 and 45: 18 mm (3/4")
 RKP 63, 80, 100 and 140: 22 mm (7/8")
 RKP 250: 35 mm (1 1/4")

Flushing the Housing

If the pump is operated at low pressure without flow for long periods ($t > 15$ min, $p < 30$ bar (435 psi), $Q = 0$ l/min), pump sizes 63 to 100 cm³/rev must be flushed with approximately 4 to 6 l/min (1 to 1.5 gpm) to dissipate the heat generated. The 140 cm³/rev pump must always be flushed with 6 to 8 l/min (1.5 to 2 gpm). The flushing line to the pump must be connected to the lower drain port. Pump size 250 cm³/rev must always be flushed with 10 to 12 l/min (2.5 to 3 gpm). For RKP 250 the flushing line to the pump must be connected to port L2.

Noise Development

Radial piston pumps have a low primary noise level. However, the overall noise level hydraulic of the unit depends on the pump mounting and piping layout and the transmitted noise can be prevented by:

- Connecting the pump to the bellhousing using an anti-vibration flange.
- Use flexible hoses instead of solid pipes.
- Clamp the pipework with elastic insert clamps.

Connections

Suction line to port A and pressure line from port B. Except for RKP 19 counterclockwise: Suction port B, pressure port A.

Putting into Service

Do not start up the pump without hydraulic fluid. Before switching on, the pump housing must be filled with hydraulic fluid using the higher drain port.

Jog start the electric motor to check the correct direction of rotation. Run the pump at low pressure until the hydraulic system has been fully de-aerated. When putting pumps for HF fluids into operation, the system must be run at low pressure of between 30 to 50 bar (435 to 725 psi) for approximately 1 hour.

Important

The oil temperature in the tank must not exceed the temperature of the pump by more than +25 °C (+77 °F).

If this should occur, the pump must be jog started for intervals of approximately 1 to 2 seconds until pump casing has heated up. When changing a pump, clean the suction pipe, drain line and tank. Refill the tank with filtered oil.

APPENDIX A – COMPENSATOR OPTIONS

1. Adjustable Pressure Compensator F1, F2

Pressure range:

F1: 30 to 105 bar (435 to 1,523 psi)

F2: 80 to 350 bar (1,160 to 5,000 psi)

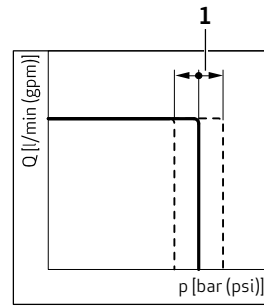
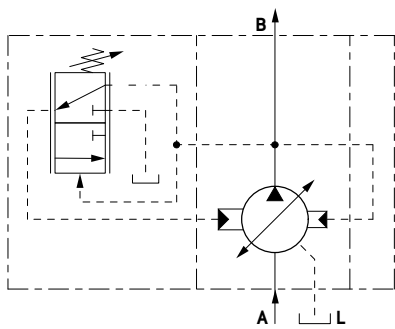

1 Screw adjustment

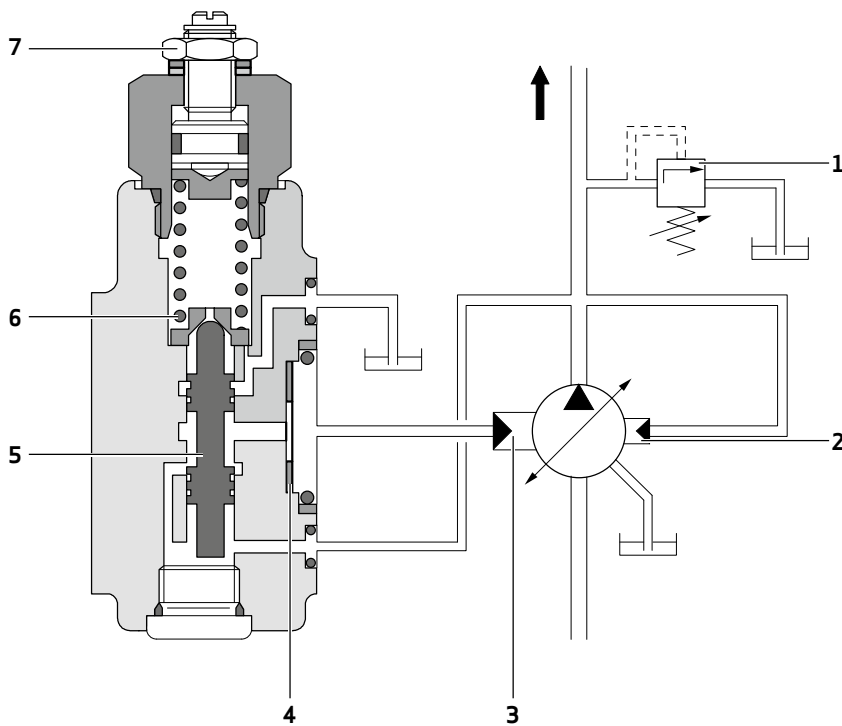

1 Safety valve $p = p_{\text{maximum}} + 30 \text{ bar (435 psi)}$

2 Control piston 2

3 Control piston 1

4 Adjustment of zero stroke

5 Valve spool

6 Valve spring

7 Adjustment screw

APPENDIX A – COMPENSATOR OPTIONS

2. Remote Pressure Compensator H1

Pressure pilot valve:

Manual remote adjustable or proportional pressure valve.
 Q = 0.5 to 1.5 l/min (0.1 to 0.4 gpm)

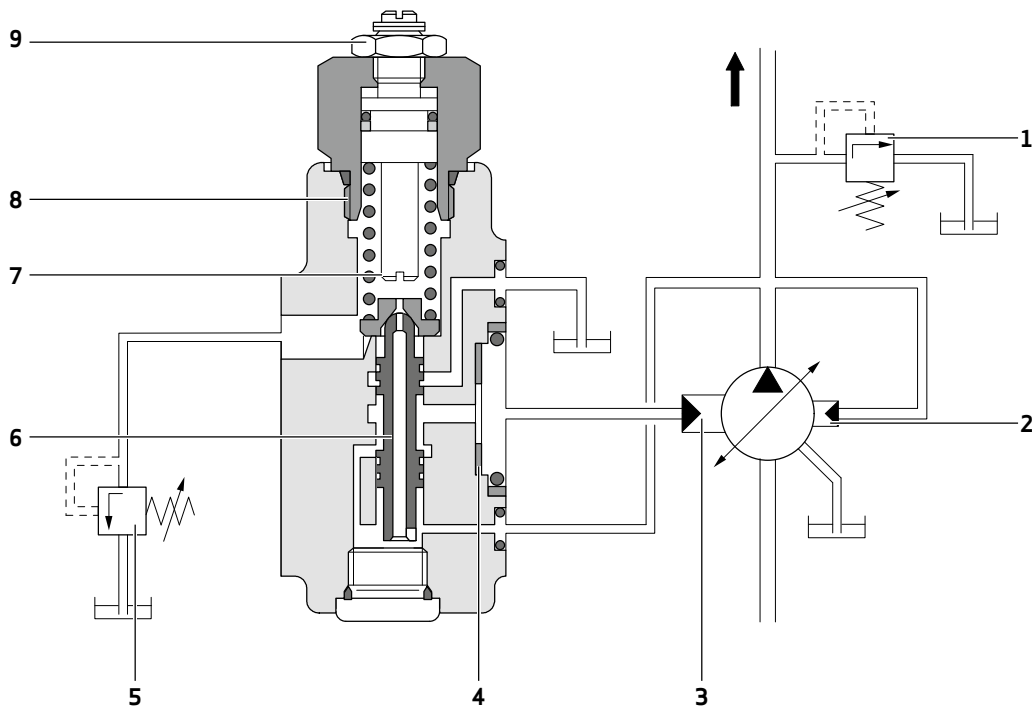
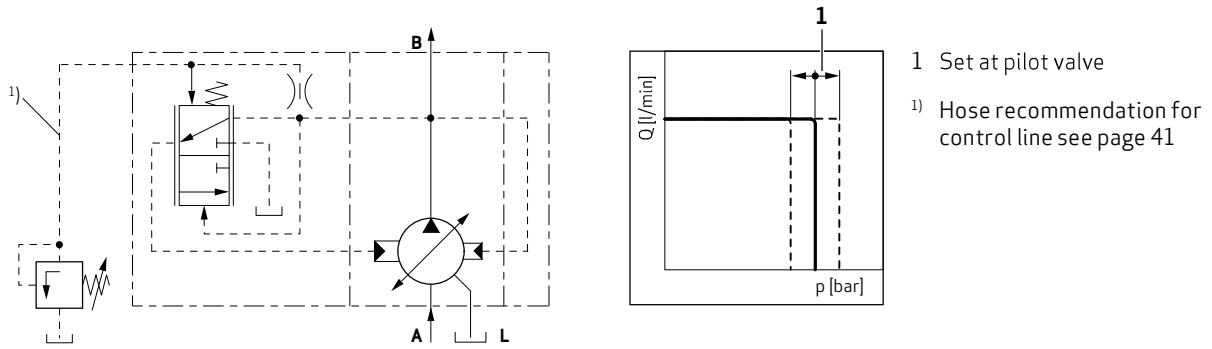

- 1 Safety valve $p = p_{\text{maximum}} + 30 \text{ bar (435 psi)}$
- 2 Control piston 2
- 3 Control piston 1
- 4 Adjustment of zero stroke
- 5 Pressure pilot valve
- 6 Valve spool
- 7 Orifice
- 8 p_{minimum} -spring
- 9 Locked screw

APPENDIX A – COMPENSATOR OPTIONS

3. Remote Pressure Compensator with Mooring Control H2

The “Mooring” control consists of a pressure compensator which has an intermediate plate inserted between the pump body and the pressure plate compensator.

The thickness of the intermediate plate corresponds to the eccentricity of the stroke ring.

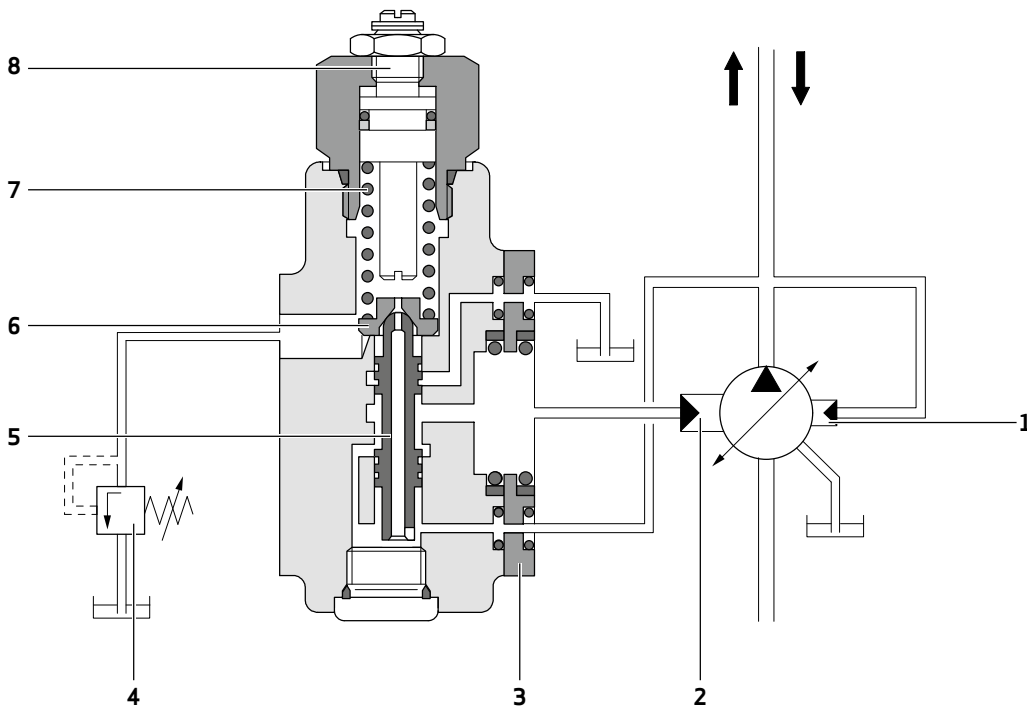
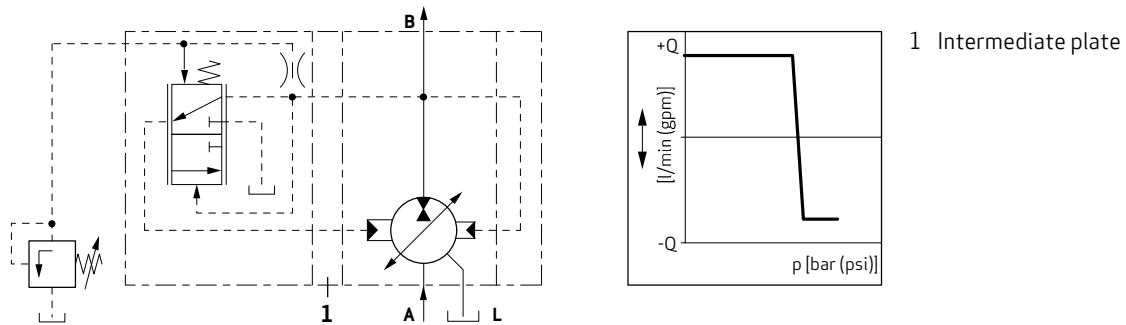

- 1 Control piston 2
- 2 Control piston 1
- 3 Intermediate plate
- 4 Pressure pilot valve

- 5 Valve spool
- 6 Orifice
- 7 p_{minimum} -spring
- 8 Locked screw

APPENDIX A – COMPENSATOR OPTIONS

4. Combined Pressure and Flow Compensator (“Load Sensing”) J1

Metering throttle:

Manual adjustable throttle valve or proportional throttle valve.

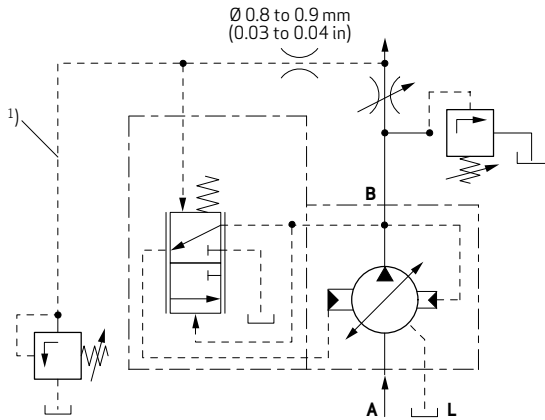

Pressure pilot valve:

Manual adjustable or proportional pressure valve.
 $Q = 0.5$ to 1.5 l/min (0.1 to 0.4 gpm)

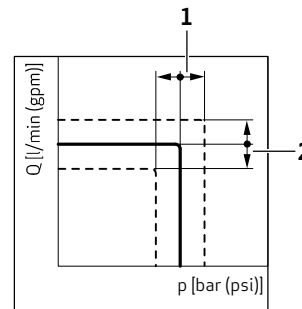

- 1 Set at pilot valve
- 2 Set at metering throttle
- 1) Hose recommendation for control line see page 41

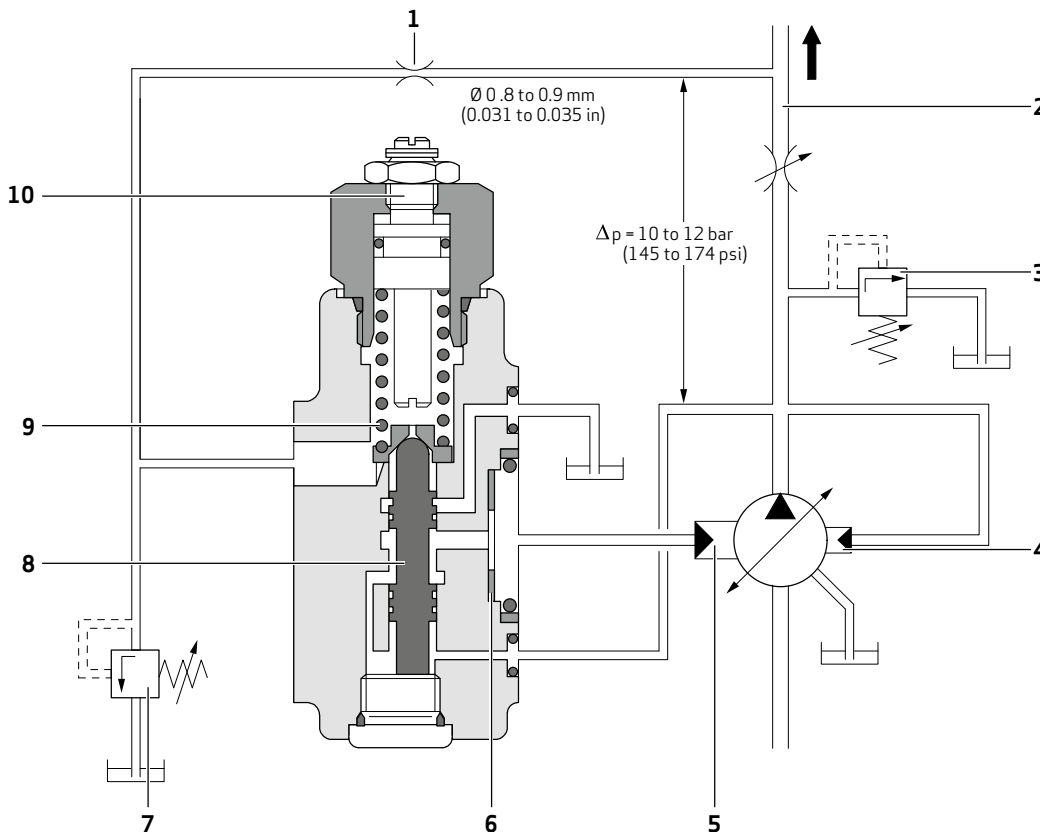

- 1 Orifice
- 2 Metering throttle for flow control
- 3 Safety valve $p = p_{\text{maximum}} + 30$ bar (435 psi)
- 4 Control piston 2
- 5 Control piston 1
- 6 Adjustment of zero stroke
- 7 Pressure pilot valve
- 8 Valve spool
- 9 Δp spring
- 10 Locked screw

APPENDIX A – COMPENSATOR OPTIONS

5. Combined Pressure and Flow Compensator with P-T Control Notch R1

Metering throttle:

Manual adjustable throttle valve or proportional throttle valve.

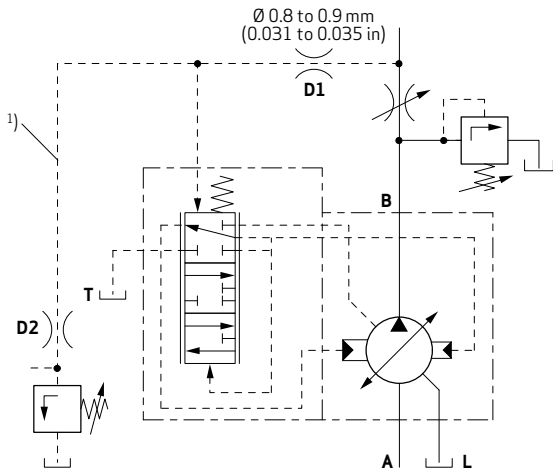

Pressure pilot valve:

Manual adjustable or proportional pressure valve.

$Q = 1$ to 1.5 l/min (0.1 to 0.4 gpm)

In multiple pumps feeding in one common line, only one compensator with P-T control notch may be installed.

This compensator must be set to a higher Δp .

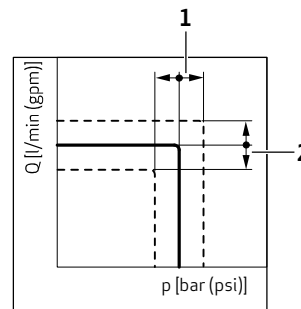

1 Set at pilot valve

2 Set at metering throttle

1) Hose recommendation for control line see page 42

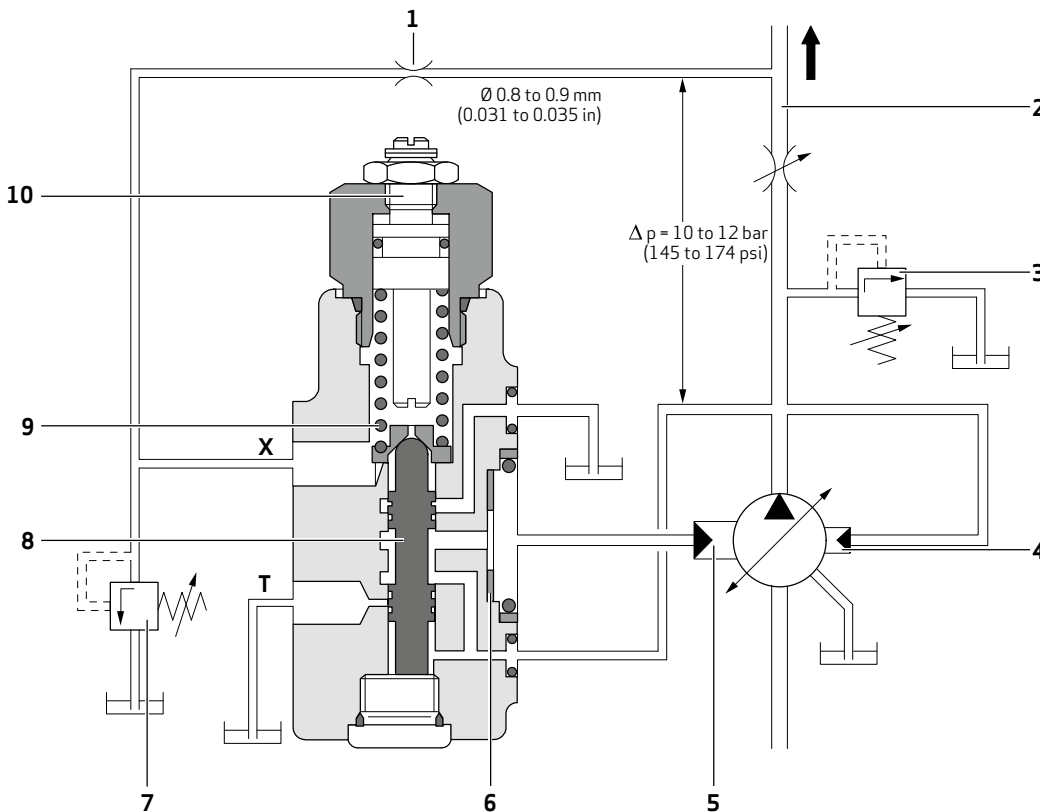

1 Orifice

2 Metering throttle for flow control

3 Safety valve $p = p_{\text{maximum}} + 30$ bar (435 psi)

4 Control piston 2

5 Control piston 1

6 Adjustment of zero stroke

7 Pressure pilot valve

8 Valve spool

9 Δp spring

10 Locked screw

APPENDIX A – COMPENSATOR OPTIONS

6. Mechanical Stroke Adjustment B1

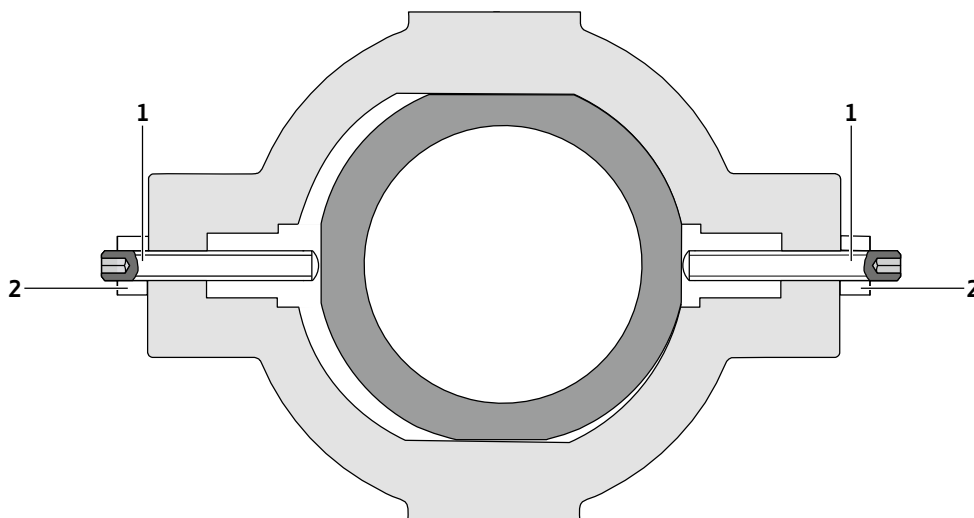
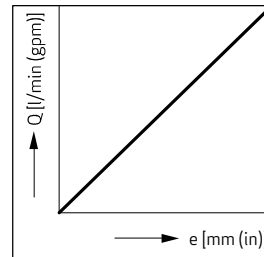
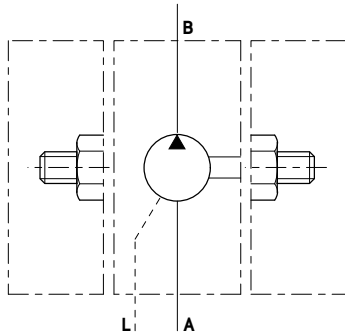

1 Adjustment screw

2 Sealing nut

	RKP 19	RKP 32	RKP 45	RKP 63	RKP 80	RKP 100	RKP 140	RKP 250
ΔV [cm ³ /rev] for 1 mm (0.04 in) travel of adjusting screw (pitch 1.5 mm/rev (0.06 in/rev))	3.4	5.5	6.4	8.6	8.7	11.1	11.3	21.9

Important

When adjusting for the required delivery, ensure that the stroke ring remains held between the two adjusting screws. When delivered, the pump is set V_{maximum} .

APPENDIX A – COMPENSATOR OPTIONS

7. Servo Control C1

Actuated manually or mechanically by means of a lever. The pump displacement is controlled by the position of the lever.

Lever is not part of delivery. Measurements for lever mounting see page 48.

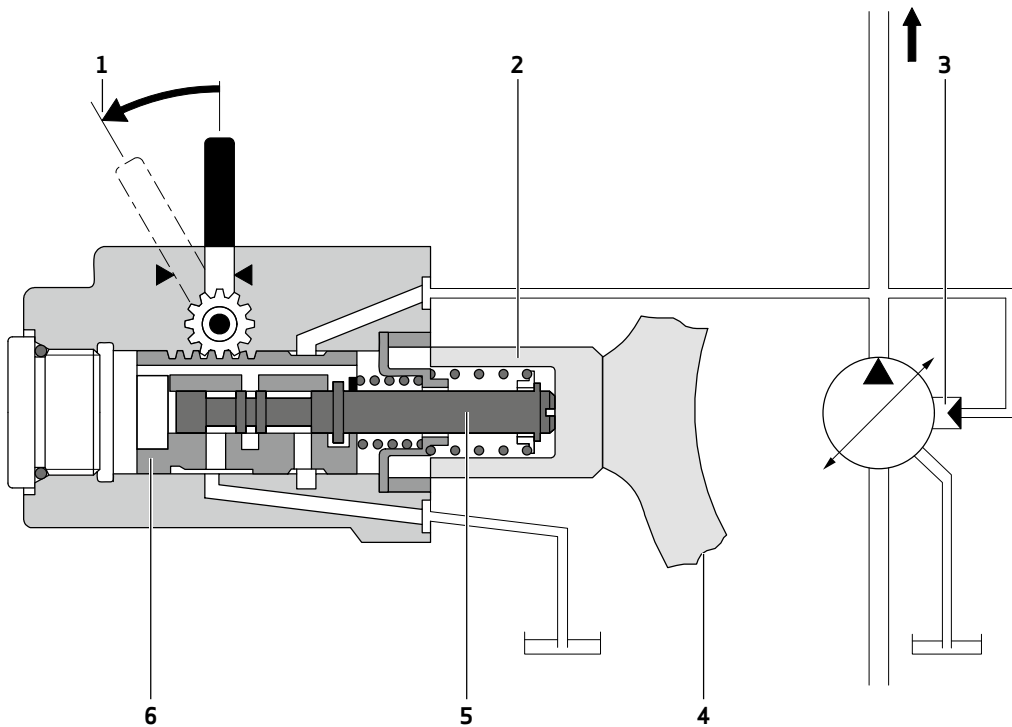
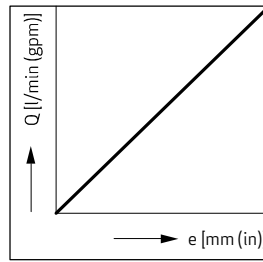
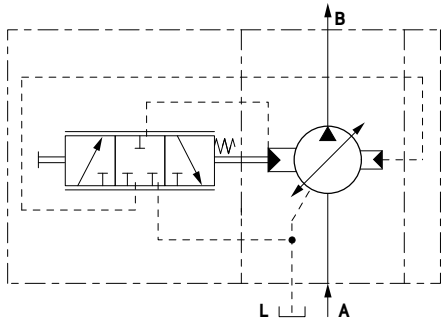

- 1 Lever for control shaft
- 2 Control piston 1
- 3 Control piston 2
- 4 Stroke ring
- 5 Pilot spool
- 6 Spool sleeve

	Control torque [Nm (lbf in)]		
	Neutral position	Final position	Maximum
RKP 19	1.2 (11)	1.7 (15)	8 (71)
RKP 32/45	1.2 (11)	1.7 (15)	8 (71)
RKP 63/80	1.6 (14)	2.4 (21)	8 (71)
RKP 100	1.6 (14)	2.4 (21)	8 (71)

APPENDIX A – COMPENSATOR OPTIONS

8. Constant Horsepower Control S1

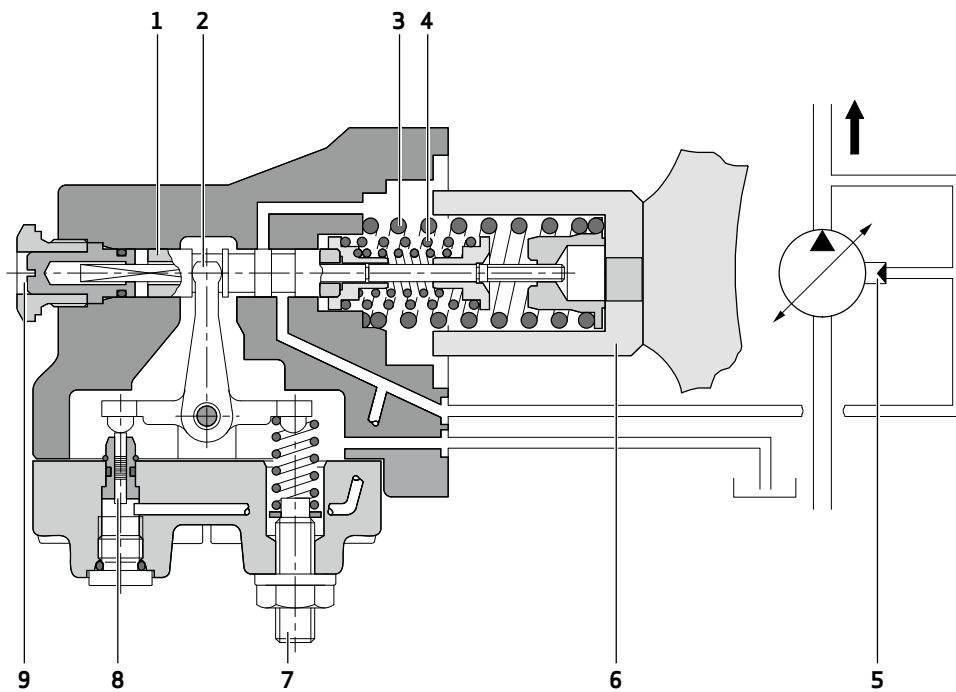
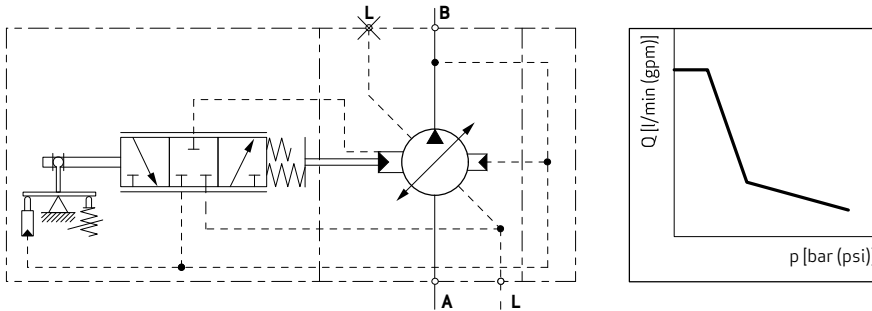

- | | |
|--------------------|---|
| 1 Pilot spool | 6 Control piston 1 |
| 2 Rocker | 7 Power set on test bench, do not change |
| 3 Spring 2 | 8 Sensing piston |
| 4 Spring 1 | 9 Power set on test bench, do not change |
| 5 Control piston 2 | |

APPENDIX A – COMPENSATOR OPTIONS

8. Constant Horsepower Control S1

V = 32 cm³/rev

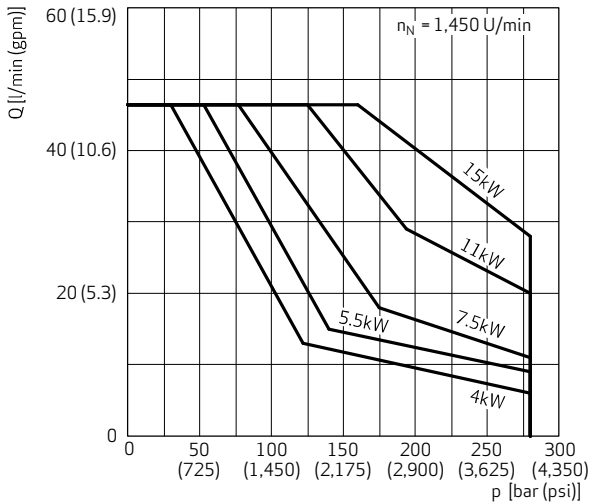

V = 100 cm³/rev

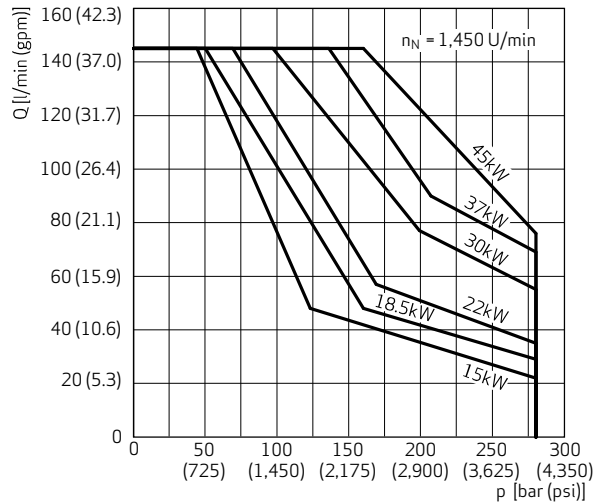

V = 45 cm³/rev

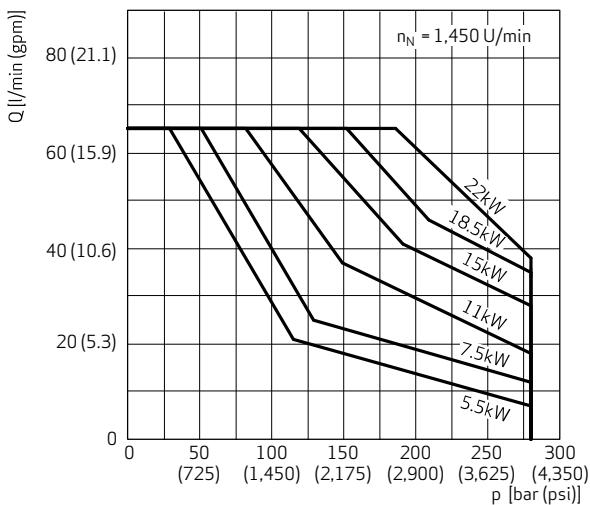

V = 140 cm³/rev

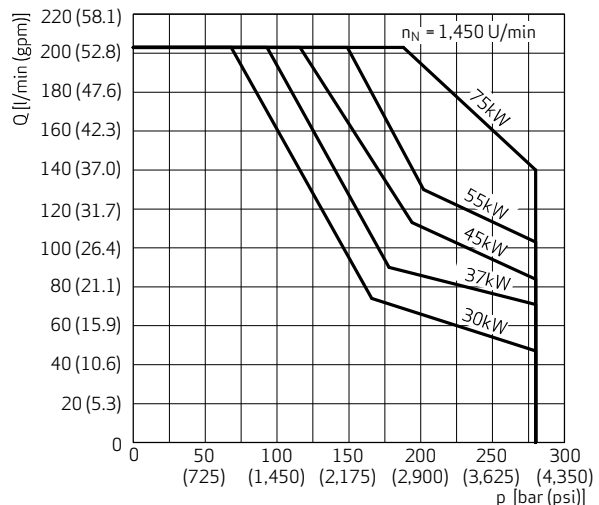

V = 63 cm³/rev

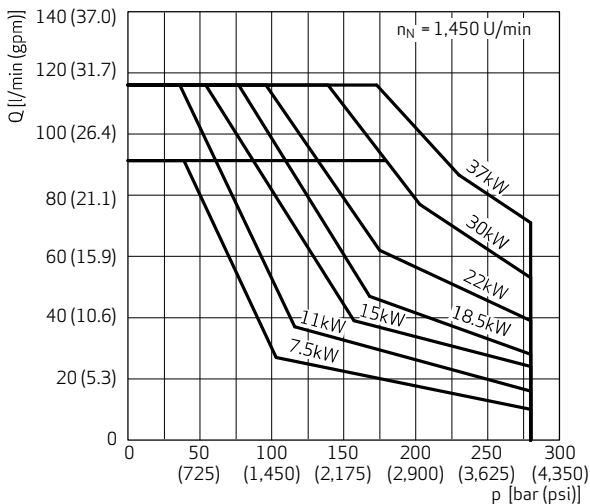

Approximation of the power hyperbola by 2 springs.

Referenced $n = 1,450 \text{ min}^{-1}$
For other speeds is valid:

$$P = \frac{P_N \cdot n}{1,450}$$

APPENDIX A – COMPENSATOR OPTIONS

9. Constant Horsepower Control with Remote Pressure and Flow Limiter S2

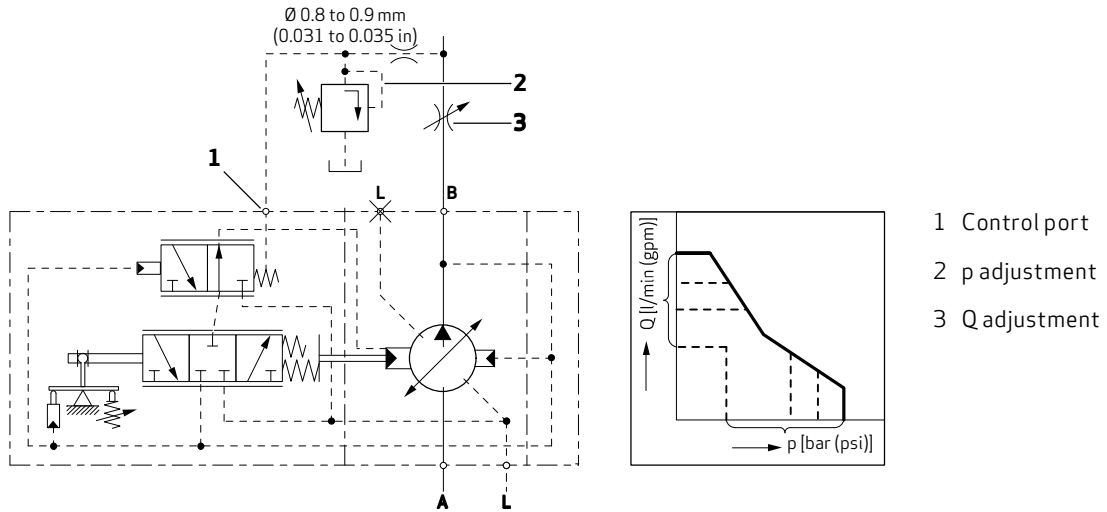

APPENDIX A – COMPENSATOR OPTIONS

10. Electro-Hydraulic Control with Digital On-Board Electronics, D1 to D8

- Control p/Q: Analog 0 to 10 V or using fieldbus
 - Pressure controller with 16 selectable parameter sets
 - 2 pressure sensors may be connected
 - Integrated horse power controller
 - Master/slave mode
 - Pressure range up to 350 bar (5,000 psi) constant pressure
- For a detailed description and other applications, see catalog for RKP with Digital Control (RKP-D).

RKP with Digital Control (RKP-D)

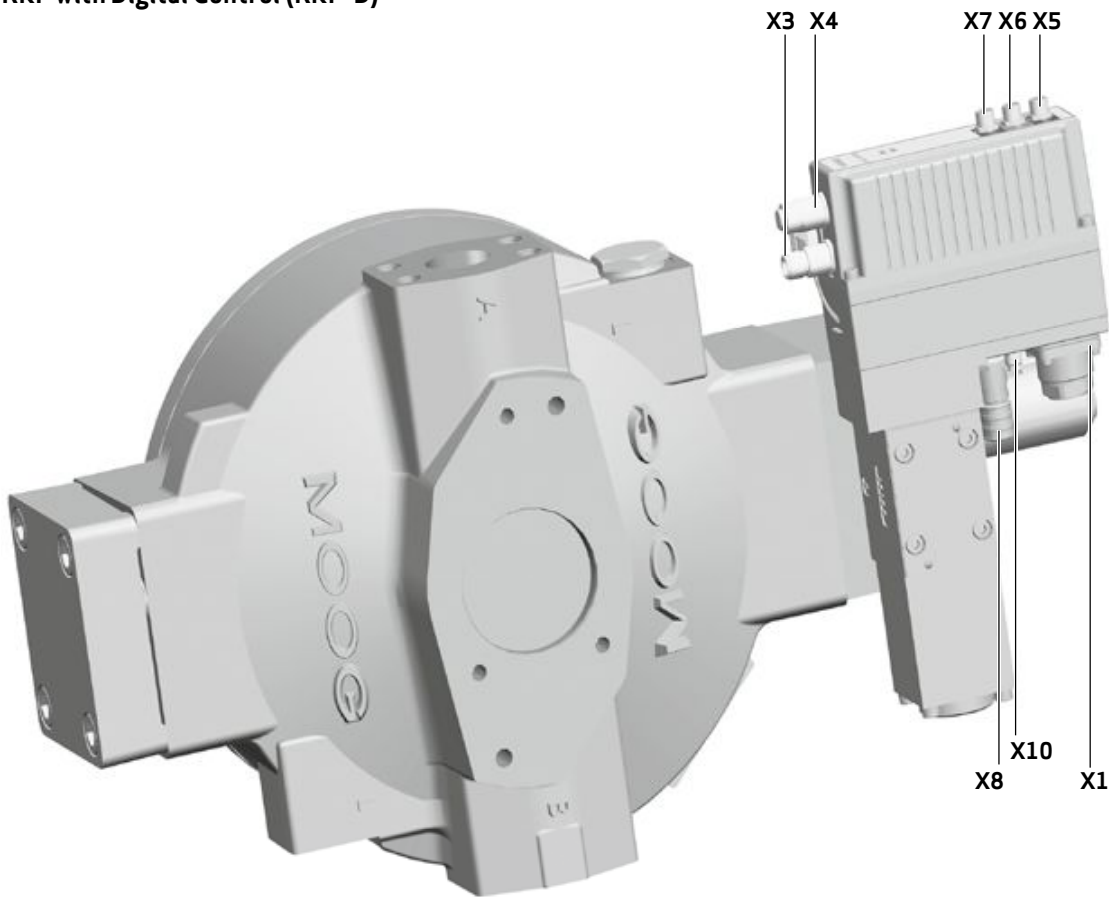

No.	Description	Type
X1	Main connector	11+PE 11-pole pin contact with PE
X3	CAN/EtherCAT	M12x1 5-pole pin contact
X4	CAN/EtherCAT	M12x1 5-pole socket contact
X5	Pressure sensor 2	M8 x 1 4-pole socket contact
X6	Pressure sensor 1	M8 x 1 4-pole socket contact
X7	Analog selection of parameter sets	M8 x 1 4-pole socket contact
X8	Linear Variable Displacement Transducer (LVDT)	M12x1 5-pole socket contact
X10	LocalCAN for master/slave operation and access via Moog Valve and Pump Configuration Software(optional)	M8 x 1 3-pole pin contact

Shielding of valve and LVDT: IP65 (with connected and locked receptacles respectively)

APPENDIX A – COMPENSATOR OPTIONS

10. Electro-Hydraulic Control with Digital On-Board Electronics, D1 to D8

Internal Pressure Supply D1

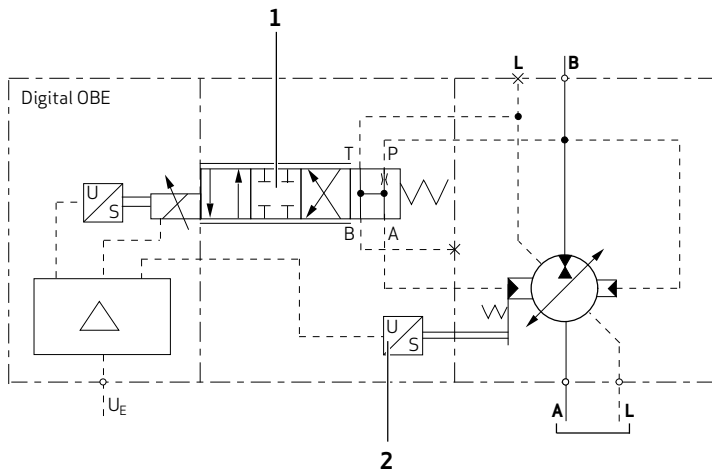

- 1 Servo pilot valve D930
- 2 Path encoder

External Pressure Supply D2

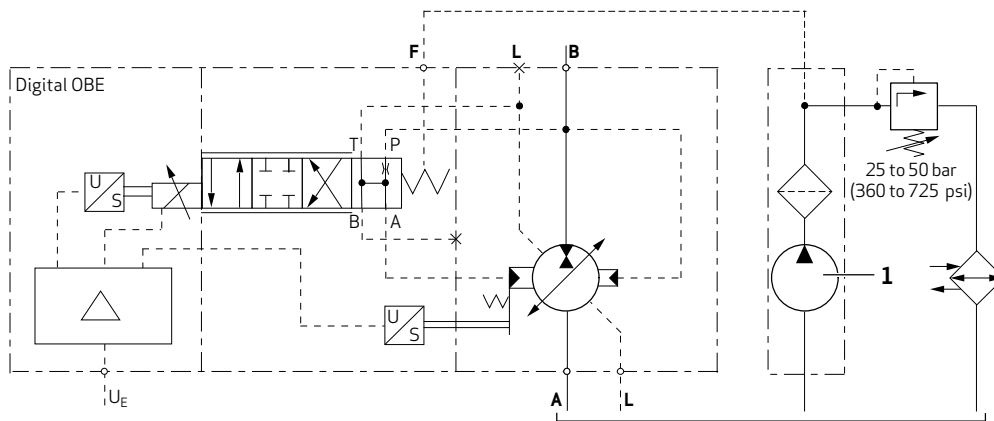

- 1 Gear pump

For more information on electro-hydraulically adjustable pumps, see catalog "RKP with Digital Control" (RKP-D).

APPENDIX A – COMPENSATOR OPTIONS

11. Dual-displacement, N1

To switch displacement volume from one defined stroking ring position to another, a switching valve is used.

The required minimum displacement volume (V_{minimum}) and maximum displacement volume (V_{maximum}) values can be mechanically set using an adjusting screw.

Factory setting: $V_{\text{minimum}} = 0.5 \times V_{\text{maximum}}$

This control option is suitable for both variable speed operation as well as displacement control with two displacement stages and a constant speed.

When used as a variable speed pump, the displacement volume can be adjusted to the respective point in the cycle by switching between V_{minimum} and V_{maximum} . As the pump drive torque is reduced with V_{minimum} , both the motor and frequency inverter may be smaller, depending on the machine cycle.

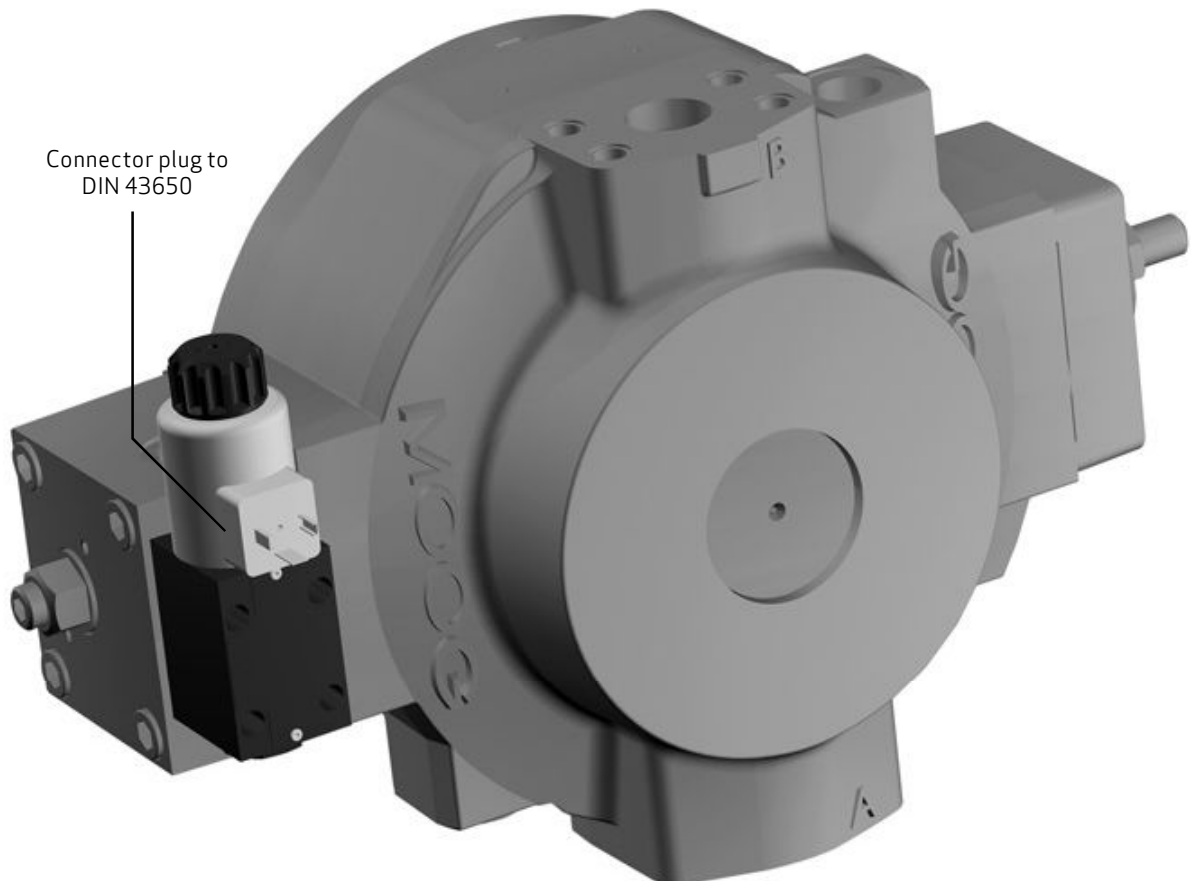
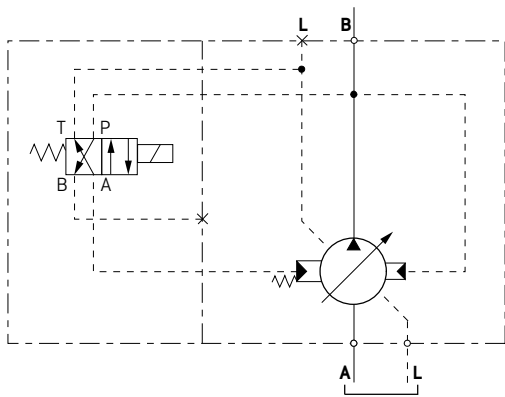

APPENDIX B – TECHNICAL DRAWINGS RKP 19 TO 100

1. Housings

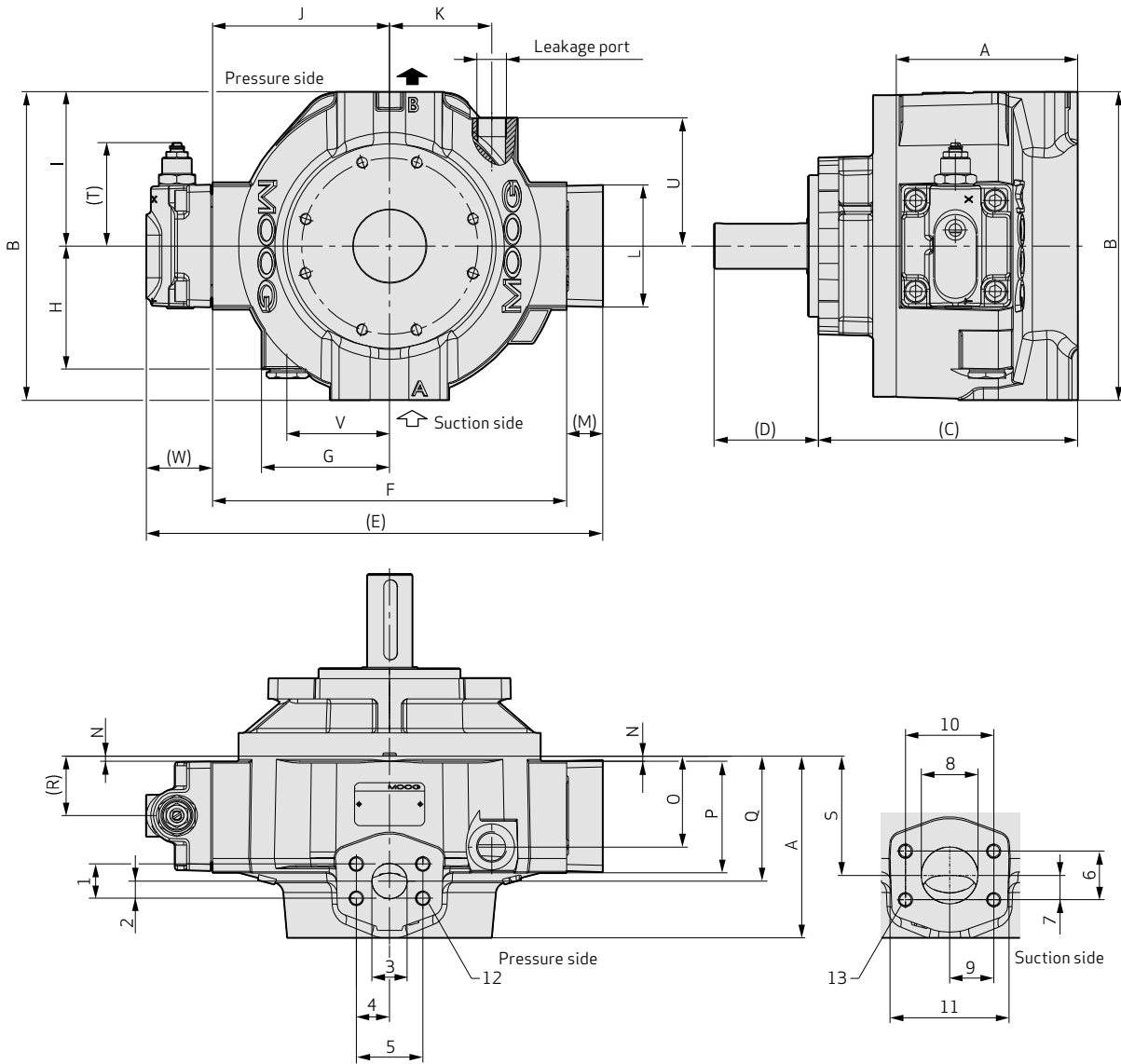

Caution! Figure presents clockwise direction.
For counterclockwise direction the compensator is build for the opposite side. Change of rotation is **not** possible.

Multiple arrangement: Example RKP 63 + RKP 32

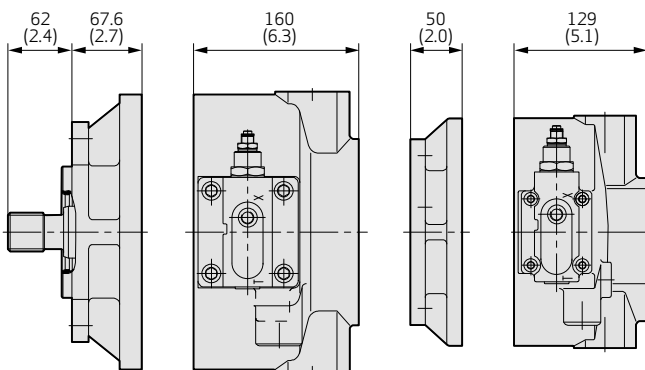

APPENDIX B – TECHNICAL DRAWINGS RKP 19 TO 100

1. Housings

[mm (in)]		RKP 19	RKP 32/45	RKP 63/80/100
Length	A	104.00 (4.09)	129.00 (5.08)	160.00 (6.30)
	Height	B	181.00 (7.13)	225.00 (8.87)
Width	(C)¹⁾	163.10 (6.43)	193.10 (7.60)	228.60 (9.00)
	(D)¹⁾	46.10 (1.81)	78.00 (3.07)	92.00 (3.62)
	(E)²⁾	290.50 (11.45)	319.30 (12.58)	402.50 (15.86)
	F	212.00 (8.35)	241.00 (9.50)	312.10 (12.30)
	G	78.00 (3.07)	97.00 (3.82)	113.00 (4.45)
	H	83.00 (3.27)	87.00 (3.42)	108.00 (4.26)
	I	90.50 (3.57)	112.50 (4.43)	136.00 (5.36)
	J	106.00 (4.18)	120.50 (4.75)	156.00 (6.14)
	K	56.00 (2.20)	84.00 (3.30)	90.00 (3.55)
	Leakage port		M18 x 1.5 (0.06) – 13 (0.51) deep	M22 x 1.5 (0.06) – 14 (0.55) deep
	L	80.00 (3.15)	81.40 (3.20)	107.70 (4.24)
	(M)²⁾	26.00 (1.02)	26.00 (1.02)	32.00 (1.26) (51.7 (2.04) at D2, D3, D6)
	N	1.00 (0.03)	7.50 (0.31)	4.30 (0.17)
	O	55.00 (2.17)	66.00 (2.60)	80.00 (3.15)
	P	70.00 (2.76)	75.50 (2.98)	98.50 (3.88)
	Q	67.00 (2.63)	88.00 (3.47)	110.00 (4.33)
	(R)²⁾	35.00 (1.38)	41.20 (1.62)	52.25 (2.06)
	S	67.00 (2.63)	85.00 (3.35)	105.00 (4.13)
	(T)²⁾	Maximum 103.00 (4.06)	Maximum 103.00 (4.06)	Maximum 98.00 (3.86)
	U	83.00 (3.27)	87.00 (3.42)	113.00 (4.45)
	V	56.00 (2.20)	78.00 (3.07)	90.00 (3.55)
(W)²⁾	52.50 (2.07)	52.30 (2.06)	58.40 (2.30)	

¹⁾ Value for flange A7

²⁾ Value for compensators F, H, J, R without maximum flow limiter

APPENDIX B – TECHNICAL DRAWINGS RKP 19 TO 100

1. Housings

[mm (in)]	RKP 19		RKP 32/45		RKP 63/80/100		
Pressure port		SAE 3/4" 3,000 psi	SAE 3/4" 6,000 psi	SAE 1" 3,000 psi	SAE 1" 6,000 psi	SAE 1 1/4" 3,000 psi	SAE 1 1/4" 6,000 psi
	1	22.20 (0.87)	23.90 (0.94)	26.20 (1.05)	27.80 (1.10)	30.16 (1.19)	31.70 (1.25)
	2	11.10 (0.44)	11.95 (0.47)	13.10 (0.52)	13.90 (0.55)	15.08 (0.59)	15.85 (0.62)
	3	19.00 (0.75)	19.00 (0.75)	25.00 (0.98)	25.00 (0.98)	26.00 (1.02)	31.00 (1.22)
	4	23.81 (0.94)	25.40 (1.00)	26.20 (1.05)	28.60 (1.13)	29.37 (1.16)	33.34 (1.31)
	5	47.60 (1.87)	50.80 (2.00)	52.40 (2.06)	57.20 (2.25)	58.74 (2.31)	66.68 (2.63)
	12	M10 16 (0.63) deep	M10 16 (0.63) deep	M10 16 (0.63) deep	M12 21 (0.83) deep	M12 21 (0.83) deep	M14 24 (0.94) deep
Suction port		SAE 3/4" 3,000 psi	SAE 3/4" 6,000 psi	SAE 1 1/2" 3,000 psi	SAE 2" 3,000 psi		
	6	22.20 (0.87)	23.90 (0.94)	35.70 (1.41)	42.80 (1.69)		
	7	11.10 (0.44)	11.95 (0.47)	17.85 (0.70)	21.40 (0.84)		
	8	19.00 (0.75)	19.00 (0.75)	38.00 (1.50)	50.00 (1.97)		
	9	23.81 (0.94)	25.40 (1.00)	34.95 (1.38)	38.90 (1.53)		
	10	47.60 (1.87)	50.80 (2.00)	69.90 (2.75)	77.80 (3.06)		
	11	71.00 (2.80)	71.00 (2.80)	98.00 (3.86)	105.00 (4.13)		
	13	M10 16 (0.63) deep	M10 16 (0.63) deep	M12 24 (0.94) deep	M12 22.5 (0.89) deep		

APPENDIX B – TECHNICAL DRAWINGS RKP 19 TO 100

2. Drive Flanges A7

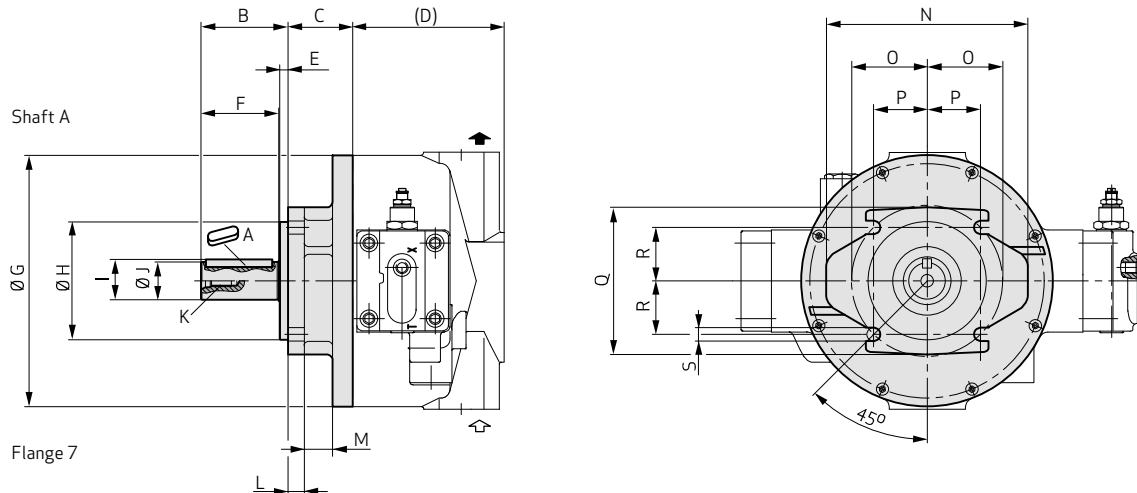

Key to DIN 6885
 ISO mounting flange to ISO 3019-2 (metric dimensions)

[mm (in)]	RKP 19	RKP 32/45	RKP 63/80/100
A	A 8 x 7 x 36 DIN 6885	A 10 x 8 x 50 DIN 6885	A 12 x 8 x 70 DIN 6885
B	52.00 (2.05)	68.00 (2.68)	92.00 (3.62)
C	58.10 (2.29)	64.10 (2.52)	68.60 (2.70)
(D)	104.00 (4.09)	129.00 (5.08)	160.00 (6.30)
E	9.00 (0.35)	9.00 (0.35)	9.00 (0.35)
F	42.00 (1.65)	58.00 (2.28)	82.00 (3.23)
G	177.00 (6.97)	220.00 (8.66)	267.00 (10.51)
H	100.00 -0.054 (3.94 -0.0021)	125.00 -0.063 (4.92 -0.0025)	125.00 -0.063 (4.92 -0.0025)
I	27.75 (1.09)	34.75 (1.37)	42.75 (1.68)
J	25.00 +0.009/-0.004 (0.98 +0.0003/-0.00016)	32.00 +0.018/+0.002 (1.26 +0.0007/+8.877 x 10 ⁻⁵)	40.00 +0.018/+0.002 (1.57 +0.0007/+8.877 x 10 ⁻⁵)
K	M8 22 (0.87) deep	M10 22 (0.87) deep	M10 32 (1.26) deep
L	11.20 (0.44)	17.20 (0.68)	17.20 (0.68)
M	30.00 (1.18)	30.00 (1.18)	30.00 (1.18)
N	174.00 (6.85)	213.00 (8.39)	213.00 (8.39)
O	62.50 (2.46)	80.00 (3.15)	80.00 (3.15)
P	44.20 (1.74)	56.58 (2.23)	56.58 (2.23)
Q	126.00 (4.96)	156.00 (6.14)	156.00 (6.14)
R	44.20 (1.74)	56.58 (2.23)	56.58 (2.23)
S	11.00 (0.43)	14.00 (0.55)	14.00 (0.55)

APPENDIX B – TECHNICAL DRAWINGS RKP 19 TO 100

3. Drive Flanges B7

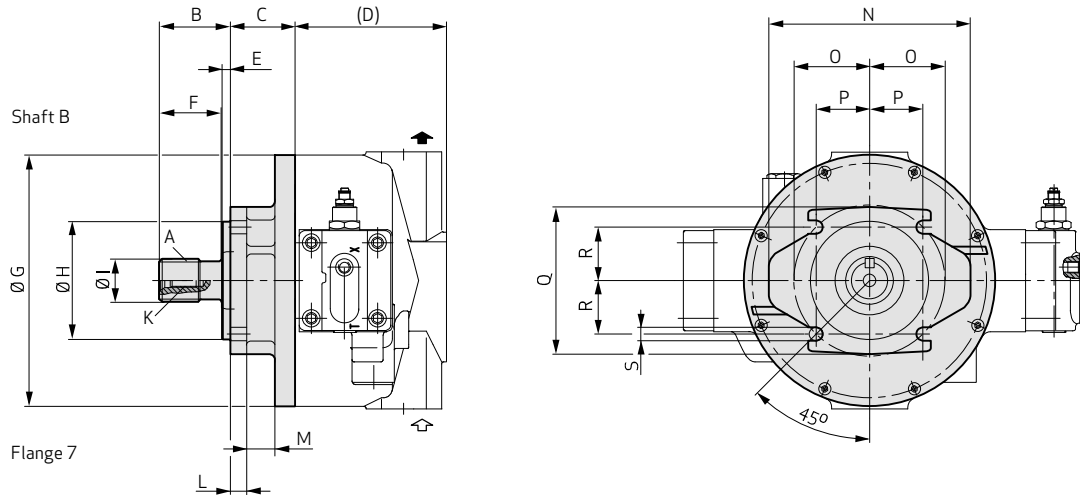

Involute spline to DIN 5480 (obligatory with multiple arrangement of RKP and SAE-B)
 ISO mounting flange to ISO 3019-2 (metric dimensions)

[mm (in)]	RKP 19	RKP 32/45	RKP 63/80/100
A	W25 x 1.25 x 30 x 18 x 8f DIN 5480	W32 x 2 x 30 x 14 x 8f DIN 5480	W40 x 2 x 30 x 18 x 8f DIN 5480
B	42.00 (1.65)	46.00 (1.81)	54.00 (2.13)
C	58.10 (2.29)	64.10 (2.52)	68.60 (2.70)
(D)	104.00 (4.09)	129.00 (5.08)	160.00 (6.30)
E	9.00 (0.35)	9.00 (0.35)	9.00 (0.35)
F	32.00 (1.26)	36.00 (1.42)	44.00 (1.73)
G	177.00 (6.97)	220.00 (8.66)	267.00 (10.51)
H	100.00 -0.054 (3.94 -0.0021)	125.00 -0.063 (4.92 -0.0024)	125.00 -0.063 (4.92 -0.0024)
I	25.00 (0.98)	32.00 (1.26)	40.00 (1.57)
K	M8 22 (0.87) deep	M10 22 (0.87) deep	M10 32 (1.26) deep
L	11.20 (0.44)	17.20 (0.68)	17.20 (0.68)
M	30.00 (1.18)	30.00 (1.18)	30.00 (1.18)
N	174.00 (6.85)	213.00 (8.39)	213.00 (8.39)
O	62.50 (2.46)	80.00 (3.15)	80.00 (3.15)
P	44.20 (1.74)	56.58 (2.23)	56.58 (2.23)
Q	126.00 (4.96)	156.00 (6.14)	156.00 (6.14)
R	44.20 (1.74)	56.58 (2.23)	56.58 (2.23)
S	11.00 (0.43)	14.00 (0.55)	14.00 (0.55)

APPENDIX B – TECHNICAL DRAWINGS RKP 19 TO 100

4. Drive Flanges C3

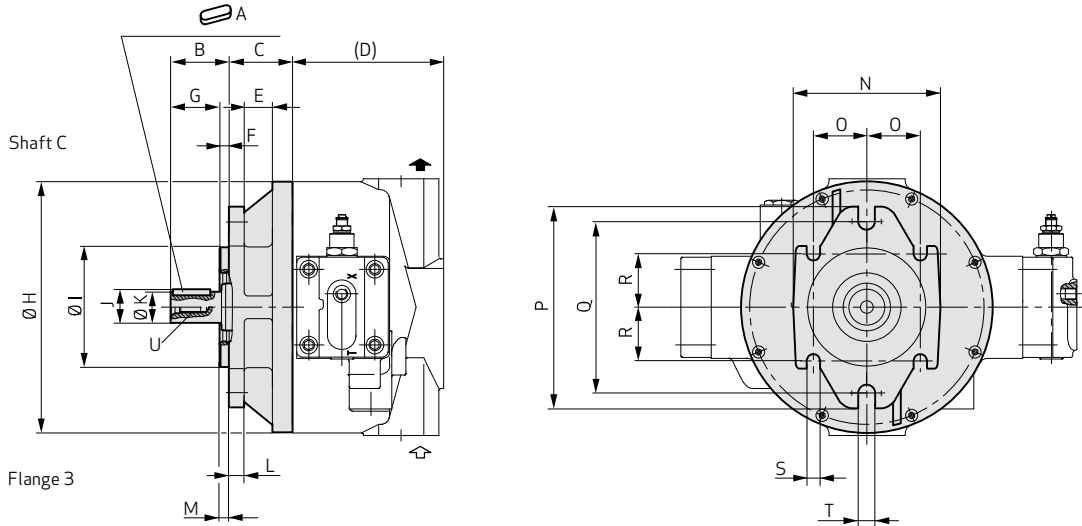

Key to SAE standard, SAE mounting flange to ISO 3019-1 (imperial dimensions)

[mm (in)]	RKP 19	RKP 32/45	RKP 63/80/100
A	6.35 x 6.35 x 25.4	7.94 x 7.94 x 32.0	9.53 x 9.53 x 42.0
B	46.10 (1.81)	57.50 (2.27)	62.00 (2.44)
C	59.10 (2.33)	63.10 (2.48)	67.60 (2.66)
(D)	104.00 (4.09)	129.00 (5.08)	160.00 (6.30)
E	30.00 (1.18)	30.00 (1.18)	30.00 (1.18)
F	8.00 (0.31)	10.00 (0.39)	10.00 (0.39)
G	36.70 (1.44)	46.00 (1.81)	54.00 (2.13)
H	177.00 (6.97)	220.00 (8.66)	267.00 (10.51)
I	101.60 -0.05 (4.00 -0.0019)	127.00 -0.05 (5.00 -0.0019)	127.00 -0.05 (5.00 -0.0019)
J	28.09 (1.11)	35.21 (1.39)	42.27 (1.66)
K	25.40 -0.05 (1.00 -0.0019)	31.75 -0.05 (1.25 -0.0019)	38.10 -0.05 (1.50 -0.0019)
L	12.20 (0.48)	16.20 (0.64)	16.20 (0.64)
M	9.40 (0.37)	11.50 (0.45)	8.00 (0.31)
N	126.00 (4.96)	156.00 (6.14)	156.00 (6.14)
O	45.00 (1.77)	57.25 (2.25)	57.25 (2.25)
P	174.00 (6.85)	213.00 (8.39)	213.00 (8.39)
Q	146.00 (5.75)	181.00 (7.13)	181.00 (7.13)
R	45.00 (1.77)	57.25 (2.25)	57.25 (2.25)
S	14.40 (0.57)	14.40 (0.57)	14.40 (0.57)
T	14.40 (0.57)	17.60 (0.69)	17.60 (0.69)
U	3/8"-16UNC-2B 22 (0.87) deep	3/8"-16UNC-2B 22 (0.87) deep	7/16"-14UNC-2B 32 (1.26) deep

APPENDIX B – TECHNICAL DRAWINGS RKP 19 TO 100

5. Drive Flanges D3

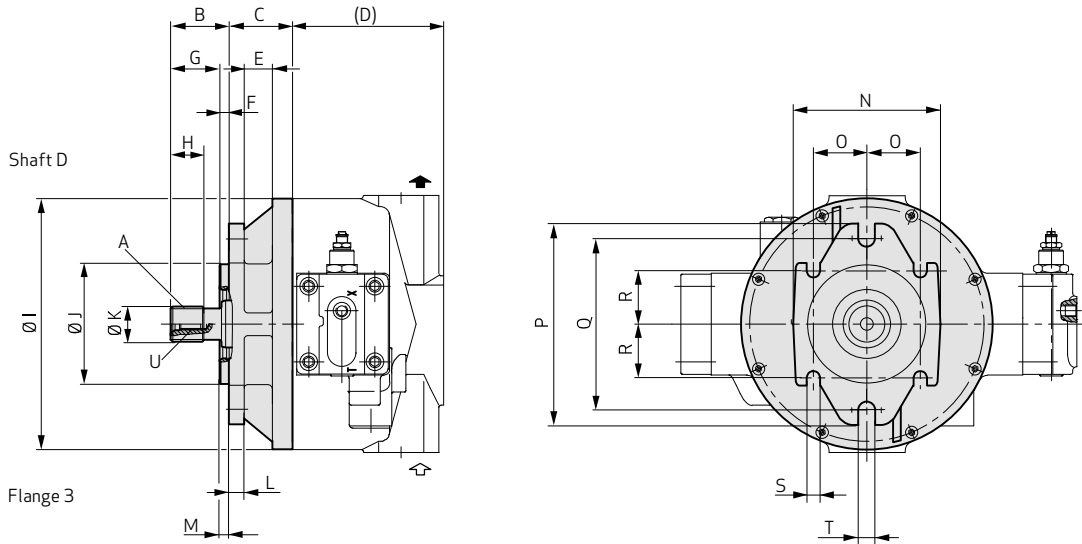

Involute spline to SAE 744 C, (obligatory with multiple arrangement of RKP and SAE-B)
 SAE mounting flange to ISO 3019-1 (imperial dimensions)

[mm (in)]	RKP 19	RKP 32/45	RKP 63/80/100
A	ANSI B92.1-1970, Class 5 30PA. 15T, 16/32DP, Flat root side fit	ANSI B92.1-1970, Class 5 30PA. 14T, 12/24DP, Flat root side fit	ANSI B92.1-1970, Class 5 30PA. 17T, 12/24DP, Flat root side fit
B	46.00 (1.81)	56.00 (2.20)	62.00 (2.44)
C	59.10 (2.33)	63.10 (2.48)	67.60 (2.66)
(D)	104.00 (4.09)	129.00 (5.08)	160.00 (6.30)
E	30.00 (1.18)	30.00 (1.18)	30.00 (1.18)
F	8.00 (0.31)	10.00 (0.39)	10.00 (0.39)
G	38.00 (1.50)	48.00 (1.89)	54.00 (2.13)
H	23.00 (0.91)	29.00 (1.14)	34.00 (1.34)
I	177.00 (6.97)	220.00 (8.66)	267.00 (10.51)
J	101.60 (4.00)	127.00 (5.00)	127.00 (5.00)
K	25.20 (0.99)	31.50 (1.24)	37.70 (1.48)
L	12.20 (0.48)	16.20 (0.64)	16.20 (0.64)
M	8.00 (0.31)	8.00 (0.31)	8.00 (0.31)
N	126.00 (4.96)	156.00 (6.14)	156.00 (6.14)
O	45.00 (1.77)	57.25 (2.25)	57.25 (2.25)
P	174.00 (6.85)	213.00 (8.39)	213.00 (8.39)
Q	146.00 (5.75)	181.00 (7.13)	181.00 (7.13)
R	45.00 (1.77)	57.25 (2.25)	57.25 (2.25)
S	14.40 (0.57)	14.40 (0.57)	14.40 (0.57)
T	14.40 (0.57)	17.60 (0.69)	17.60 (0.69)
U	3/8"-16UNC-2B 22 (0.87) deep	3/8"-16UNC-2B 22 (0.87) deep	7/16"-14UNC-2B 32 (1.26) deep

APPENDIX B – TECHNICAL DRAWINGS RKP 19 TO 100

6. Drive Flanges A1

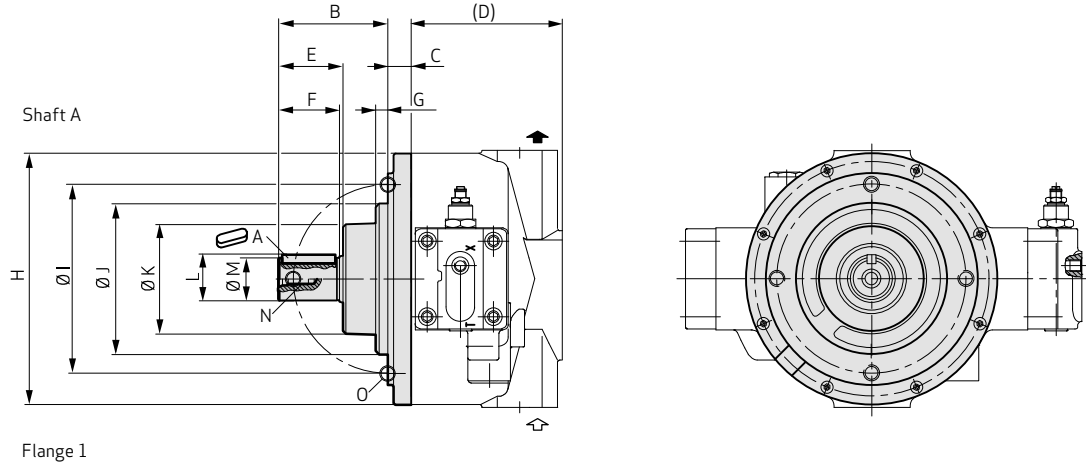

Key to DIN 6885
Metric round flange

[mm (in)]	RKP 19	RKP 32/45	RKP 63/80/100
A	A 8 x 7 x 32 DIN 6885	A 10 x 8 x 45 DIN 6885	A 14 x 9 x 56 DIN 6885
B	70.70 (2.78)	94.50 (3.72)	116.00 (4.57)
C	17.10 (0.67)	18.10 (0.71)	24.70 (0.97)
(D)	104.00 (4.09)	129.00 (5.08)	160.00 (6.30)
E	42.90 (1.69)	57.50 (2.27)	68.50 (2.70)
F	41.20 (1.62)	55.00 (2.17)	65.00 (2.56)
G	11.40 (0.45)	11.00 (0.43)	13.00 (0.51)
H	177.00 (6.97)	220.00 (8.66)	267.00 (10.51)
I	125.00 ±0.15 (4.92 ±0.0059)	160.00 ±0.15 (6.30 ±0.0059)	200.00 ±0.15 (7.87 ±0.0059)
J	100.00 -0.036/-0.09 (3.94 -0.0014/-0.0035)	125.00 -0.043/-0.106 (4.92 -0.0017/-0.0041)	160.00 -0.043/-0.106 (6.30 -0.0017/-0.0041)
K	79.00 (3.11)	101.00 (3.98)	116.00 (4.57)
L	30.75 (1.21)	37.85 (1.49)	48.40 (1.91)
M	28.00 -0.013 (1.10 -0.0005)	35.00 -0.016 (1.38 -0.0006)	45.00 -0.016 (1.77 -0.0006)
N	M10 22 (0.87) deep	M10 22 (0.87) deep	M10 32 (1.26) deep
O	M10 15 (0.59) deep	M12 16 (0.63) deep	M16 23 (0.91) deep

APPENDIX B – TECHNICAL DRAWINGS RKP 19 TO 100

7. Drive Flanges B1

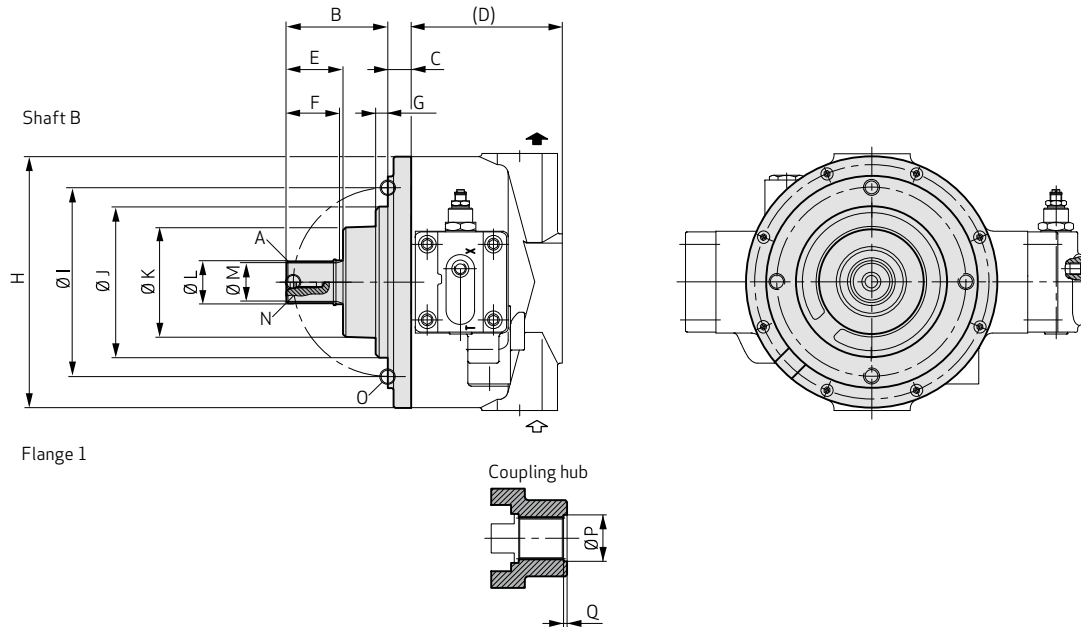

Involute spline to DIN 5482, (obligatory with multiple arrangement of RKP and SAE-B), Metric round flange

[mm (in)]	RKP 19	RKP 32/45	RKP 63/80/100
A	B 28 x 25 e9 DIN 5482	B 35 x 31 e9 DIN 5482	B 45 x 41 e9 DIN 5482
B	72.60 (2.86)	95.50 (3.76)	107.90 (4.25)
C	17.10 (0.67)	18.10 (0.71)	24.70 (0.97)
(D)	104.00 (4.09)	129.00 (5.08)	160.00 (6.30)
E	44.80 (1.76)	58.50 (2.30)	60.40 (2.38)
F	30.00 (1.18)	40.00 (1.57)	50.00 (1.97)
G	11.40 (0.45)	11.00 (0.43)	13.00 (0.51)
H	177.00 (6.97)	220.00 (8.66)	267.00 (10.51)
I	125.00 ±0.15 (4.92 ±0.0059)	160.00 ±0.15 (6.30 ±0.0059)	200.00 ±0.15 (7.87 ±0.0059)
J	100.00 -0.036/-0.09 (3.94 -0.0014/-0.0035)	125.00 -0.043/-0.106 (4.92 -0.0017/-0.0041)	160.00 -0.043/-0.106 (6.30 -0.0017/-0.0041)
K	79.00 (3.11)	101.00 (3.98)	116.00 (4.57)
L	30.80 ±0.25 (1.21 ±0.0098)	38.50 ±0.25 (1.52 ±0.0098)	48.45 ±0.25 (1.91 ±0.0098)
M	27.50 -0.13 (1.08 -0.0051)	34.44 -0.16 (1.36 -0.0051)	44.50 -0.16 (1.75 -0.0051)
N	M10 22 (0.87) deep	M10 22 (0.87) deep	M10 32 (1.26) deep
O	M10 15 (0.59) deep	M12 16 (0.63) deep	M16 23 (0.91) deep
P	31.30 +0.20 (1.23 ±0.0078)	39.00 +0.20 (1.53 ±0.0078)	49.00 +0.20 (1.93 ±0.0078)
Q	4.00 (0.16)	4.00 (0.16)	4.00 (0.16)

APPENDIX B – TECHNICAL DRAWINGS RKP 19 TO 100

8. Intermediate Drive Flange XX (RKP-RKP)

RKP 19/32/45

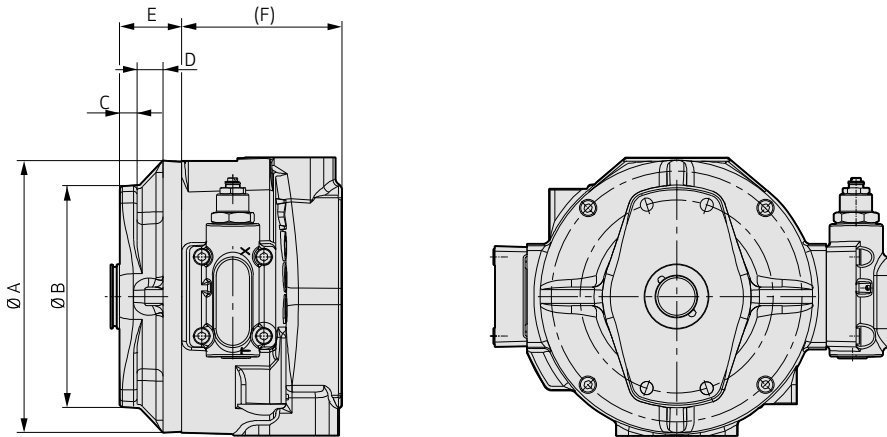

RKP 63/80/100

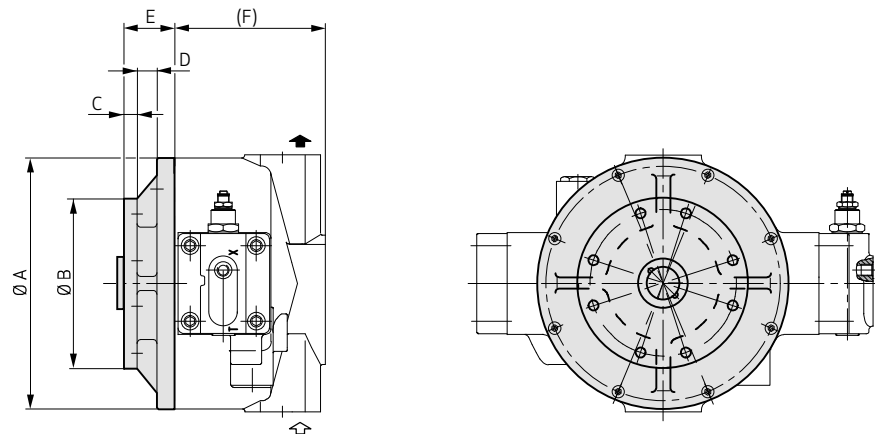

[mm (in)]	RKP 19	RKP 32/45	RKP 63/80/100
A	177.00 (6.97)	220.00 (8.66)	266.00 (10.47)
B	180.00 (7.09)	180.00 (7.09)	180.00 (7.09)
C	14.00 (0.55)	14.00 (0.55)	14.00 (0.55)
D	23.50 (0.93)	21.00 (0.83)	21.00 (0.83)
E	50.00 (1.97)	50.00 (1.97)	53.50 (2.11)
(F)	104.00 (4.09)	129.00 (5.08)	160.00 (6.30)

APPENDIX B – TECHNICAL DRAWINGS RKP 19 TO 100

9. Compensators

Adjustable Pressure Compensator F1, F2

Remote Pressure Compensator H1

Combined Pressure and Flow Compensator J1, J2

Combined Pressure and Flow Compensator with P-T Control Notch R1

RKP 19/32/45

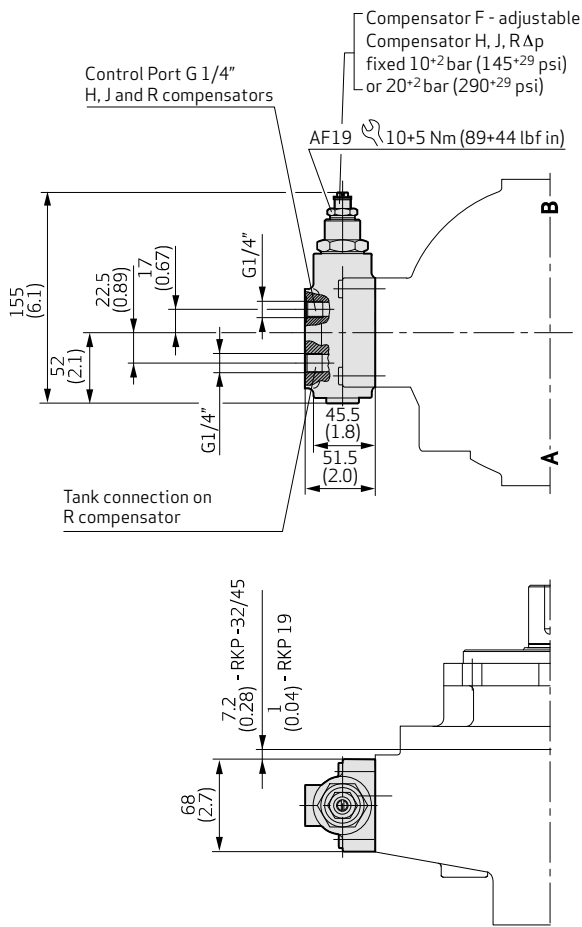

RKP 63/80/100

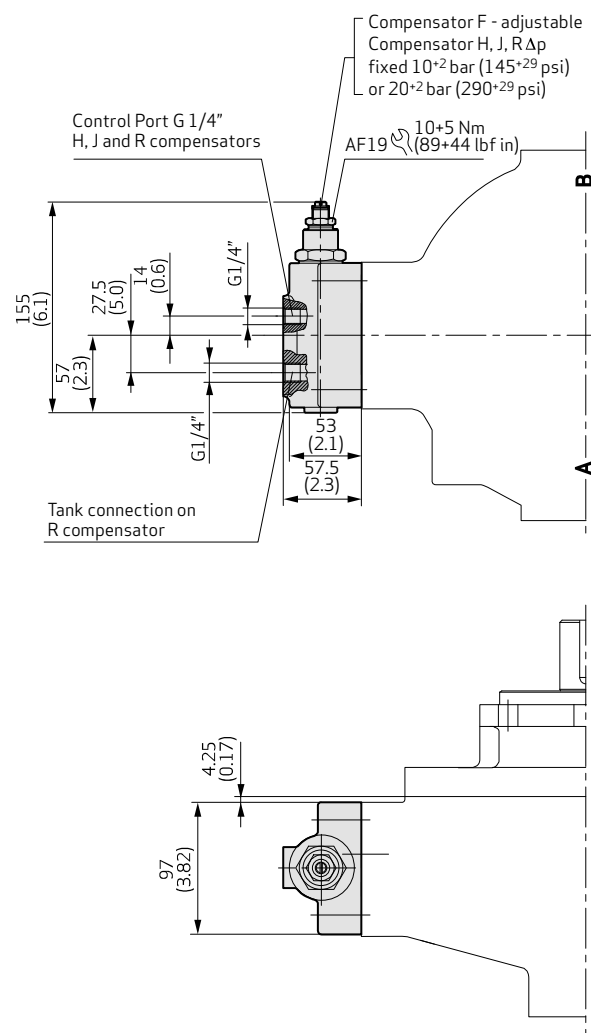

APPENDIX B – TECHNICAL DRAWINGS RKP 19 TO 100

9. Compensators

Adjustable Pressure Compensator F1, F2

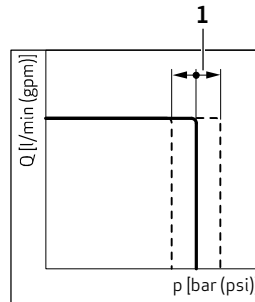
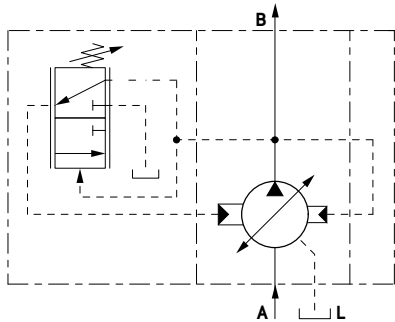

1 Screw adjustment

Remote Pressure Compensator H1

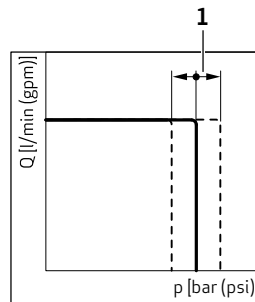
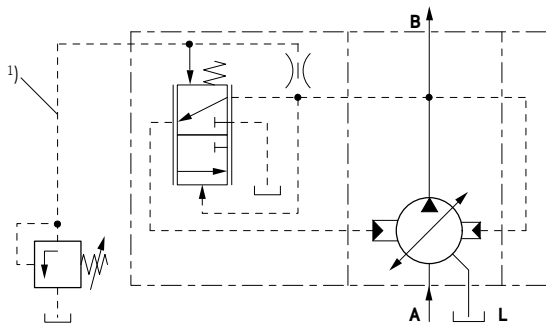

1 Set at pilot valve
1) Hose recommendation for control line, see table below

Combined Pressure and Flow Compensator J1, J2

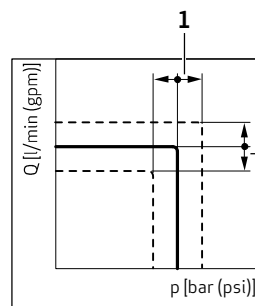
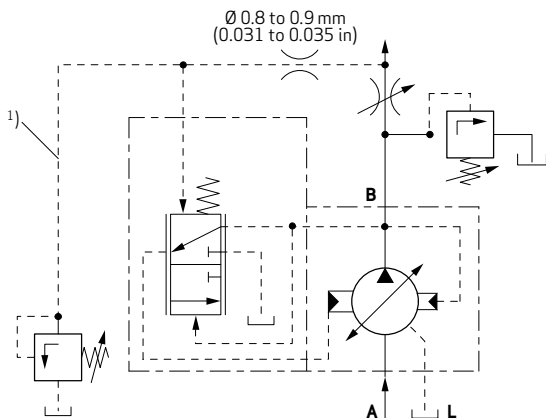

1 Set at pilot valve
2 Set at metering throttle
1) Hose recommendation for control line, see table below

When high dynamics are required for flow control, adjust orifice and control line accordingly.

RKP 19	DN 6
RKP 32, RKP 45	DN 8
RKP 63, RKP 80, RKP 100	DN 10
Length = 800 mm (31.50 in)	

APPENDIX B – TECHNICAL DRAWINGS RKP 19 TO 100

9. Compensators

Combined Pressure and Flow Compensator with P-T Control Notch R1

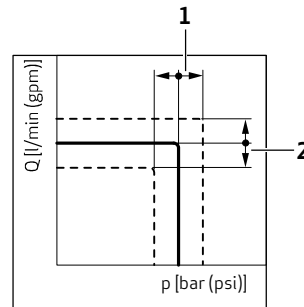
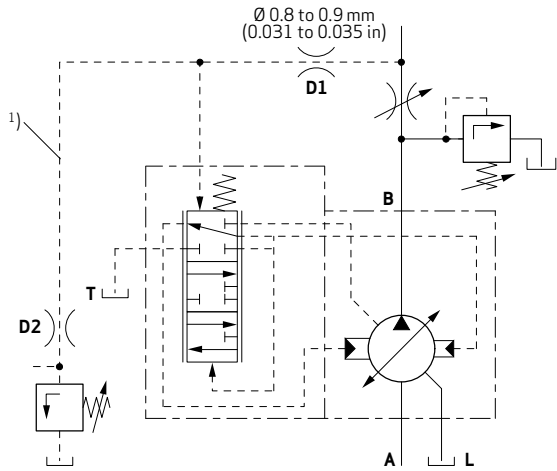

- 1 Screw adjustment
- 2 Set at metering throttle
- 1) Hose recommendation for control line, see table below

		D1 [mm (in)]	D2 [mm (in)]
RKP 19 to 45	DN 6	0.9 (0.04)	1.2 (0.05)
RKP 63 to 100	DN 8	0.9 (0.04)	1.2 (0.05)
Length = 800 mm (31.50 in)			

Notes on Multiple Pump Circuits

In the case of multiple pumps, which deliver into one circuit, the P-T control notch may only be activated for the compensator of the first pump by connecting the T-connection to the tank. The T-connection of the compensators of add-on pumps must be sealed off.

Caution!

The tank line of the compensator must not be combined with the drain line of the pump.

APPENDIX B – TECHNICAL DRAWINGS RKP 19 TO 100

9. Compensators

Adjustable Pressure Compensator, Lockable Knob with H Key G1, G2

RKP 19/32/45

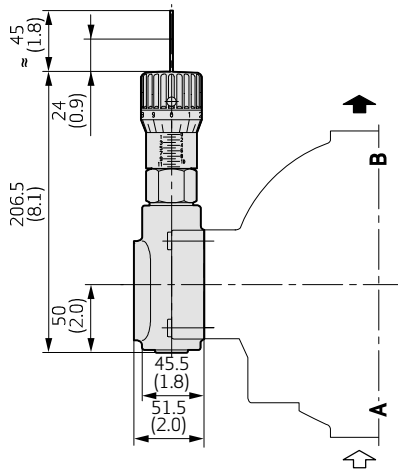

RKP 63/80/100

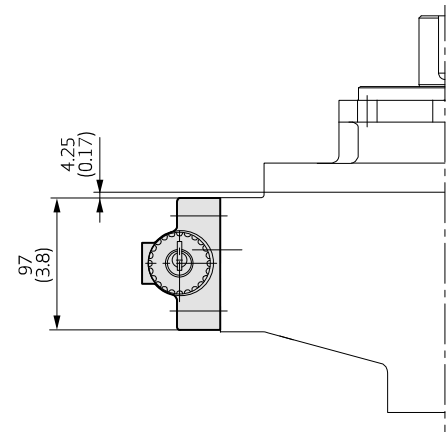
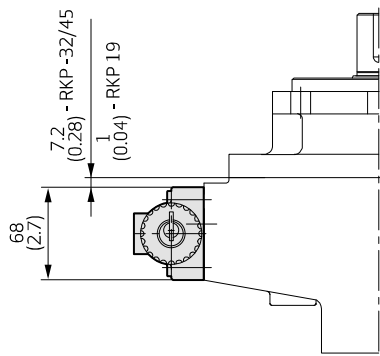
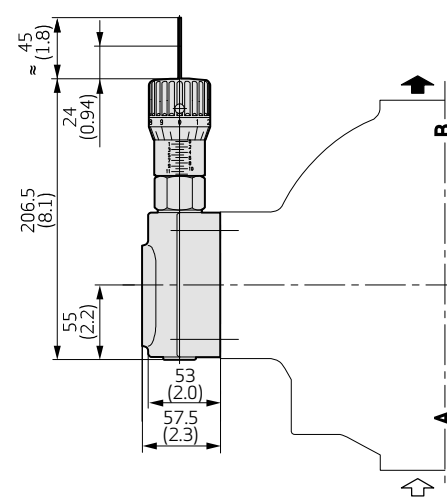

APPENDIX B – TECHNICAL DRAWINGS RKP 19 TO 100

9. Compensators

Electro-Hydraulic Control with Digital On-Board Electronics D1 to D8

RKP 19/32/45

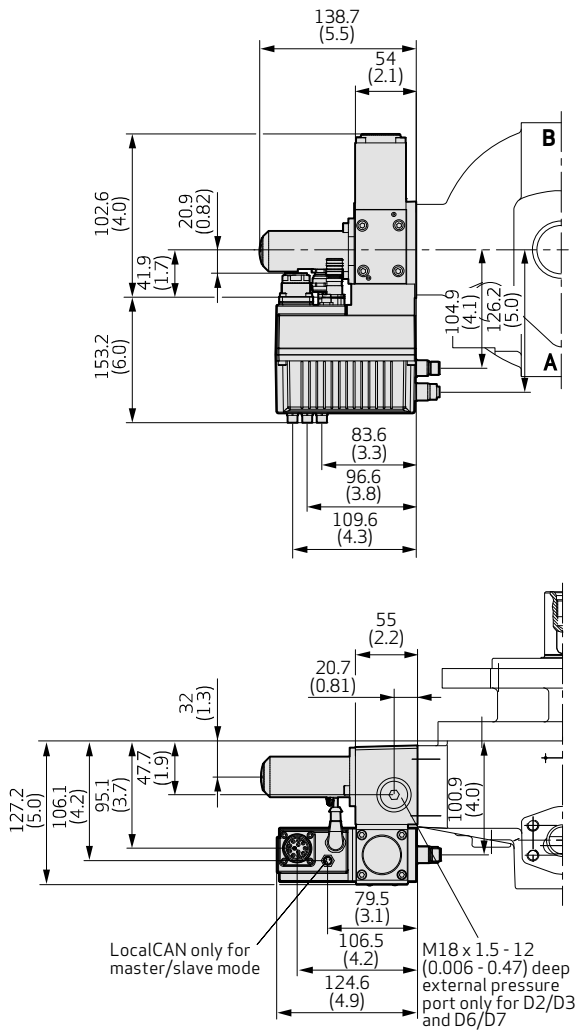

RKP 63/80/100

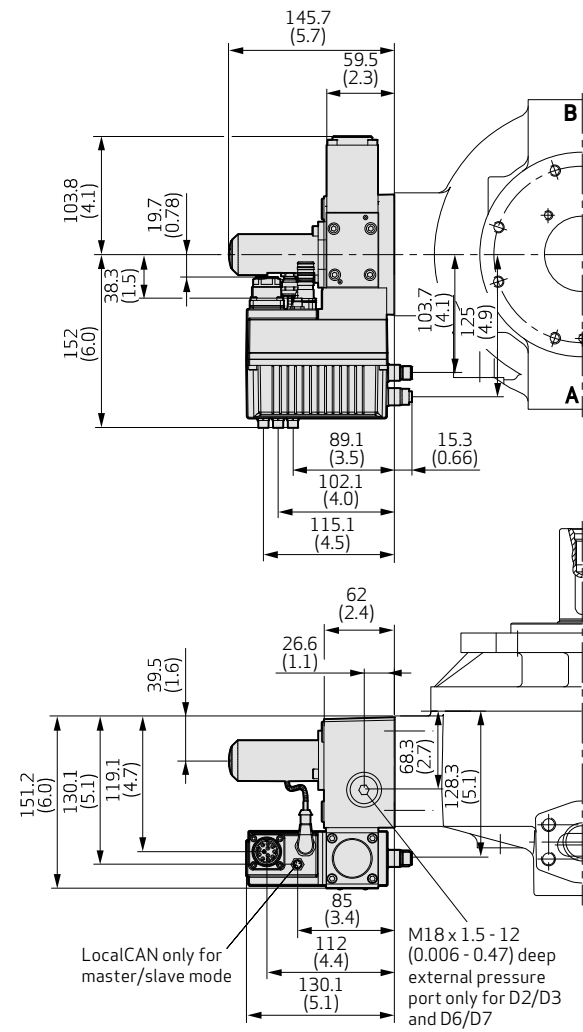

APPENDIX B – TECHNICAL DRAWINGS RKP 19 TO 100

9. Compensators

Constant Horsepower Control S1

RKP 32

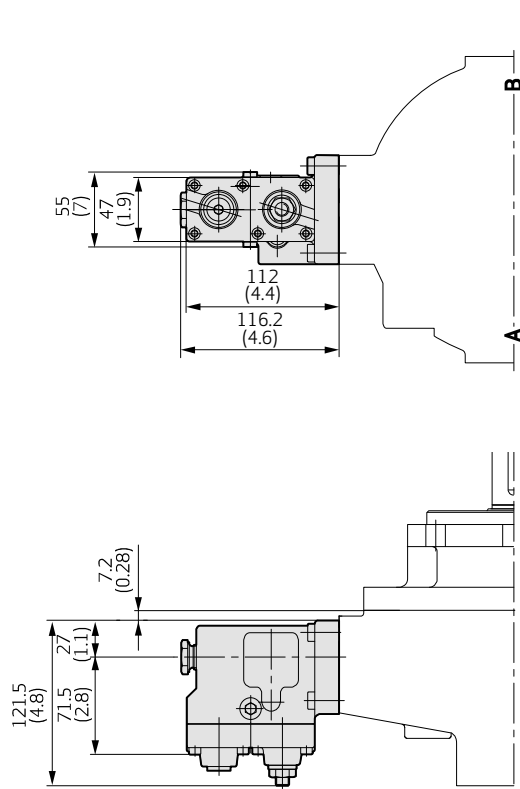

RKP 63/100

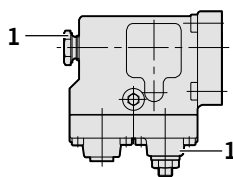
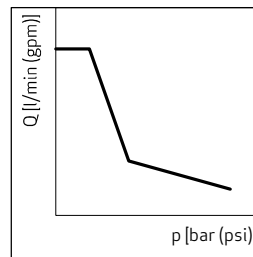
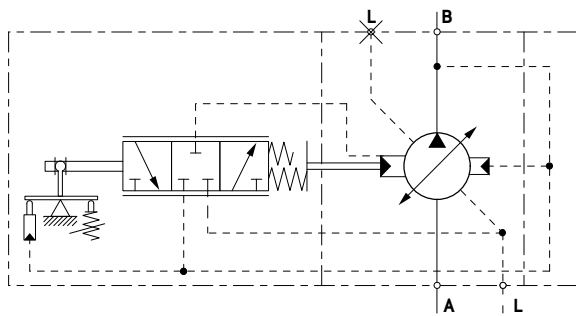
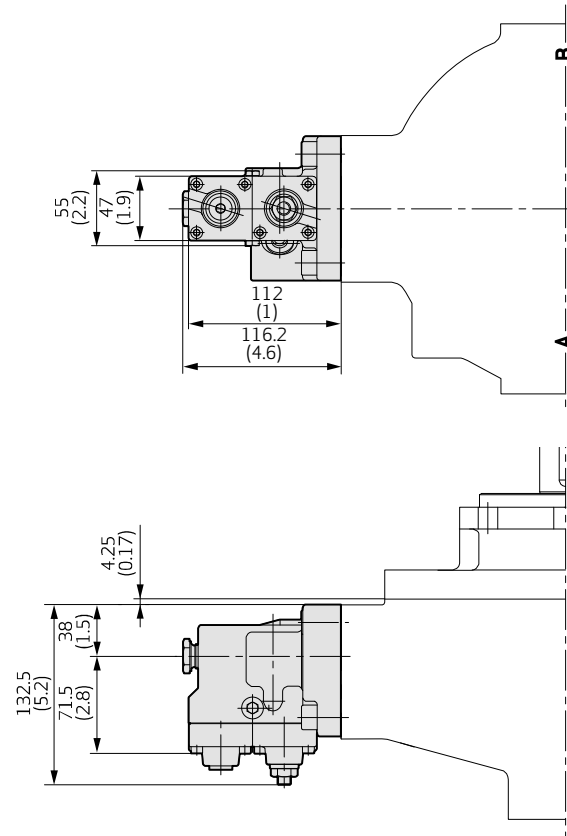

1 Horsepower adjustment (set at factory, do not change)

APPENDIX B – TECHNICAL DRAWINGS RKP 19 TO 100

9. Compensators

Constant Horsepower Control with Remote Pressure and Flow Control S2

RKP 32

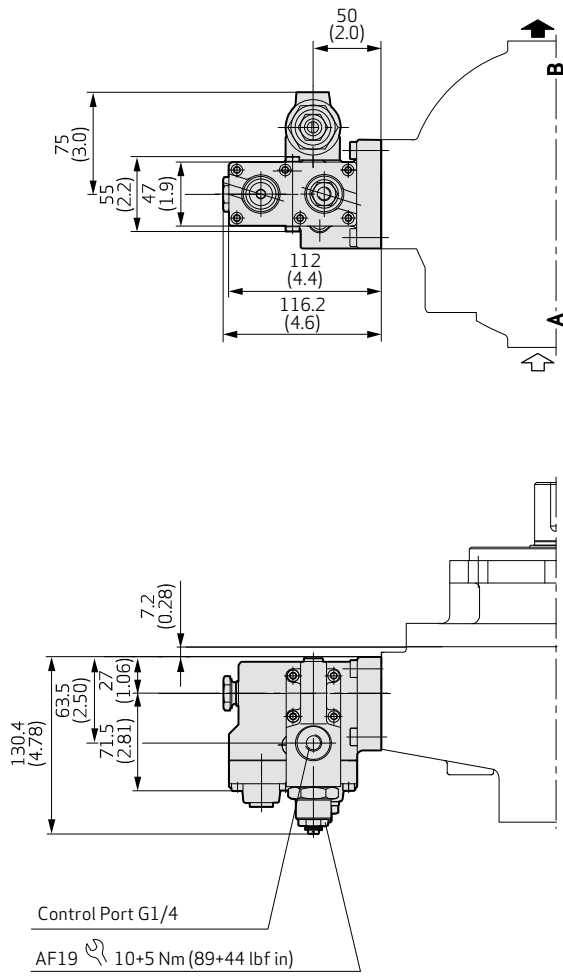

RKP 63/100

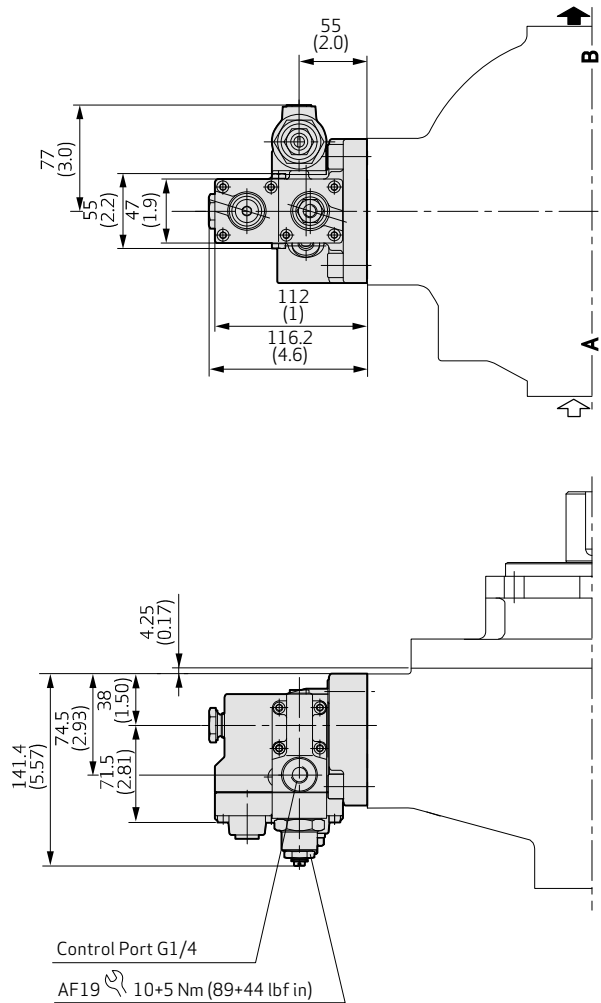

APPENDIX B – TECHNICAL DRAWINGS RKP 19 TO 100

9. Compensators

Constant Horsepower Control with Remote Pressure and Flow Control S2

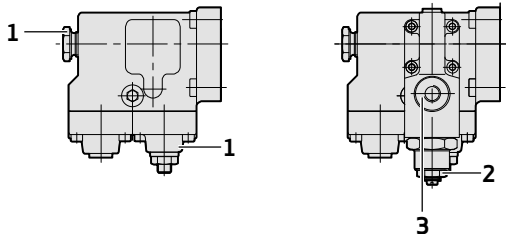
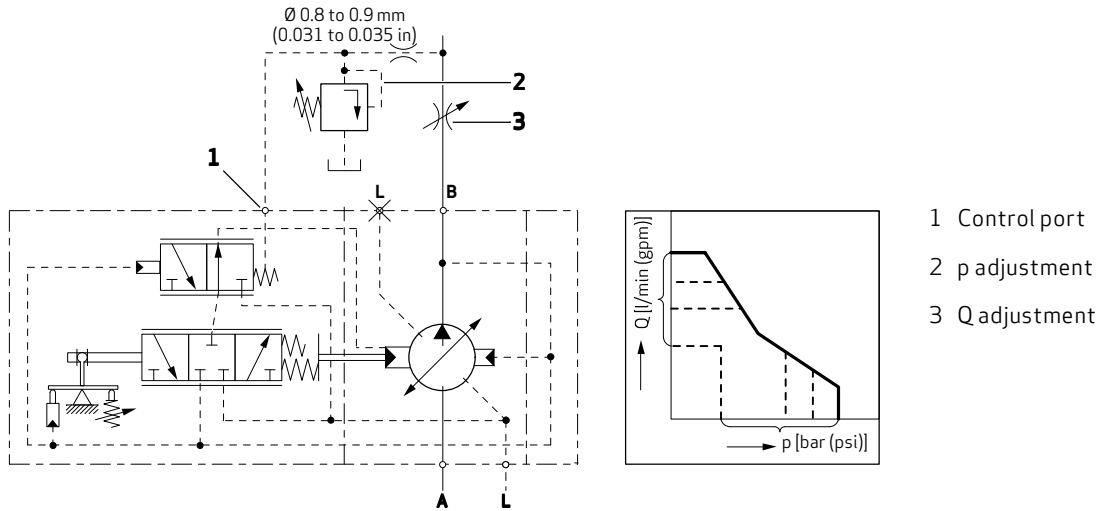

- 1 Horsepower adjustment (set at factory, do not change)
- 2 Set at factory ($\Delta p = 10^{+2}$ bar (145^{+29} psi))
- 3 Control port
For control line information, see H and J controller details.

APPENDIX B – TECHNICAL DRAWINGS RKP 19 TO 100

9. Compensators

Servo Control C1

RKP 19/32/45

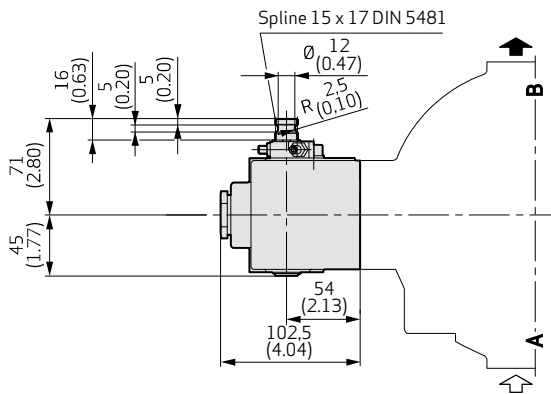

RKP 63/80/100

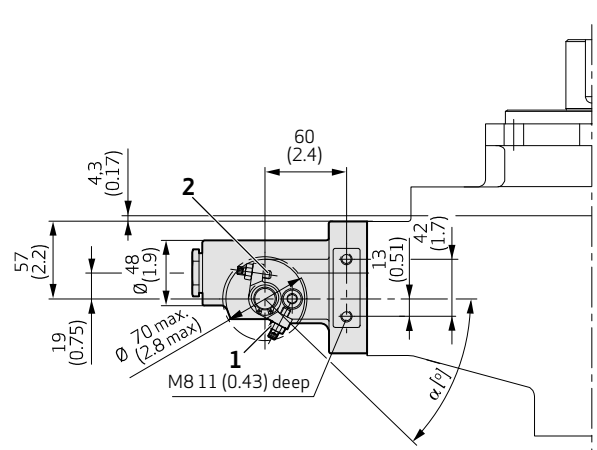
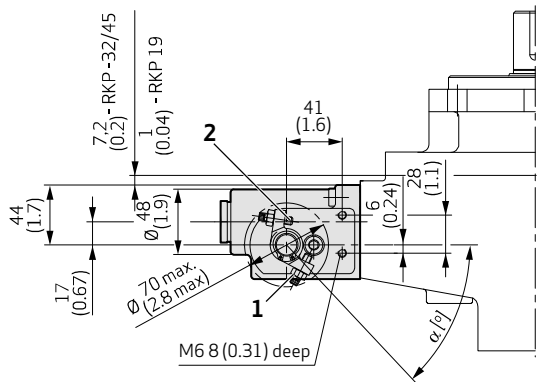
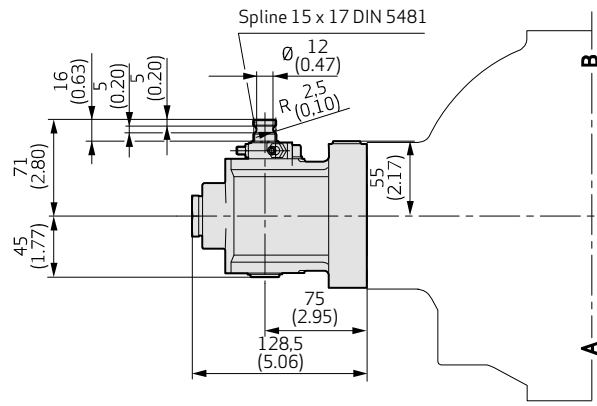

	V [cm ³ /rev]	19	32	45	63	80	100
	α [°]	44	47	57	44	56	56
Torque M [Nm (lbf in)]	Zero position	1.2 (11)			1.6 (14)		
	End position	1.6 (14)	1.7 (15)		2.4 (21)	2.6 (23)	2.6 (23)
	Maximum	8 (71)					

- 1 Zero stroke stop (set at factory)
- 2 End stop/±V_{maximum} (set at factory)

APPENDIX B – TECHNICAL DRAWINGS RKP 19 TO 100

9. Compensators

Maximum Flow Limiter Y

RKP 19/32/45

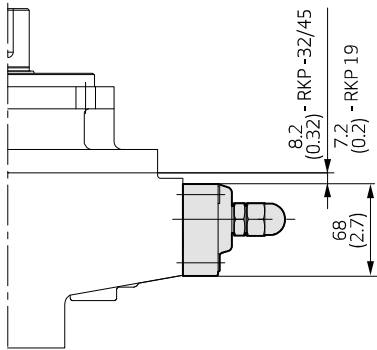
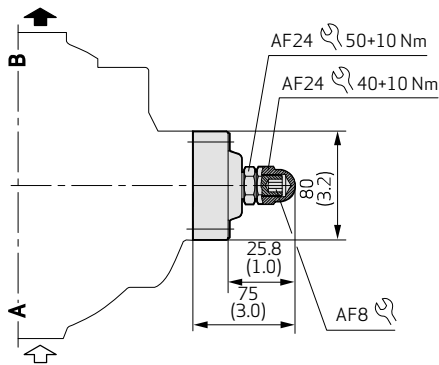

RKP 63/80/100

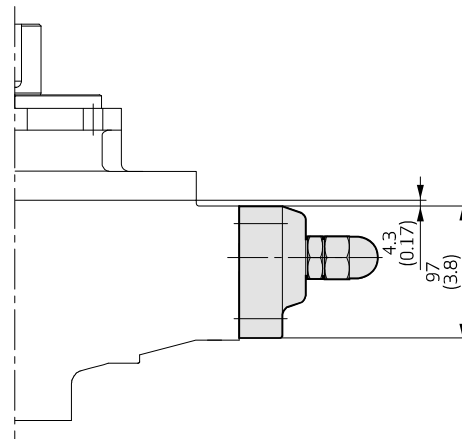
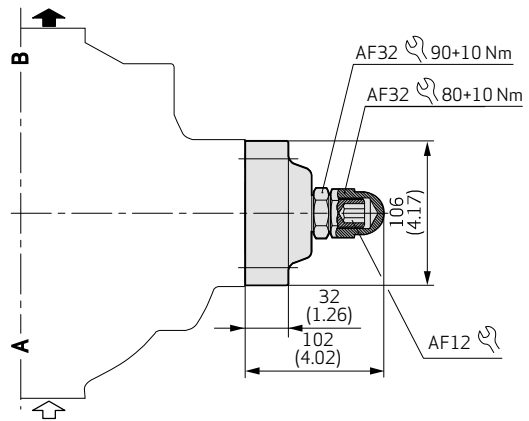

	RKP 19	RKP 32	RKP 45	RKP 63	RKP 80	RKP 100
ΔV [cm ³ /rev] for 1 mm (0.04 in) travel of adjusting screw (pitch 1.5 mm/rev (0.06 in/rev))	3.4	5.5	6.4	8.6	8.7	11.1

APPENDIX B – TECHNICAL DRAWINGS RKP 19 TO 100

9. Compensators

Mechanical Stroke Adjustment B1

RKP 19 - 100

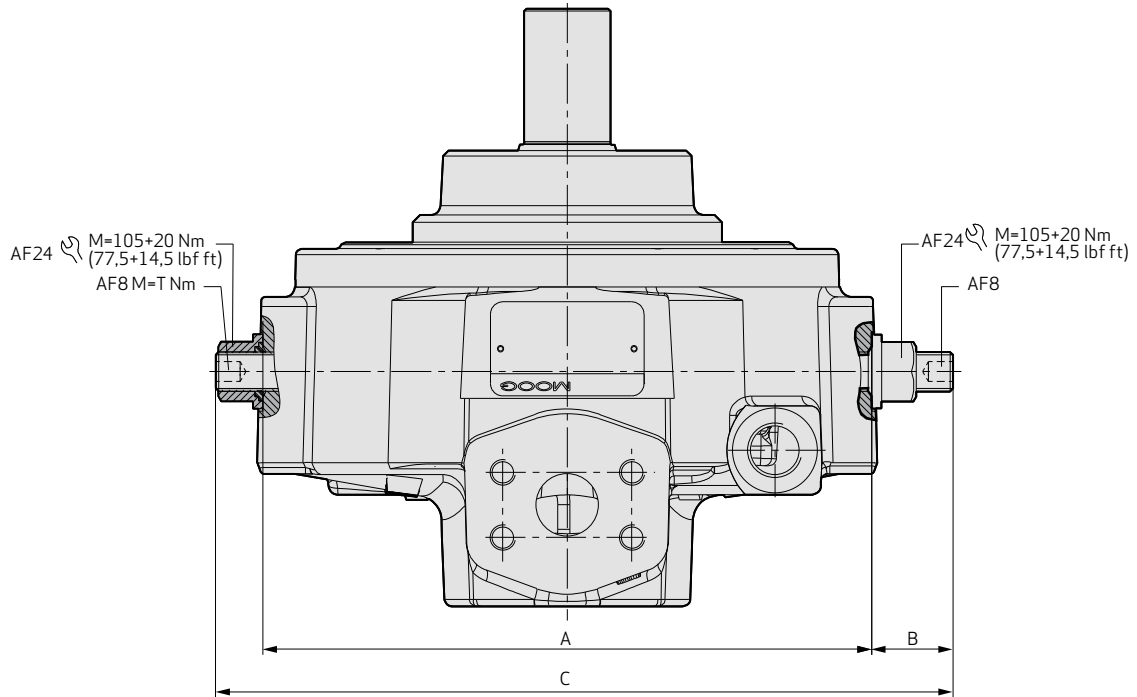

	RKP 19	RKP 32	RKP 45	RKP 63	RKP 80	RKP 100
A [mm (in)]	212 (7.95)	246 (9.69)	246 (9.69)	312 (12.28)	312 (12.28)	312 (12.28)
B [mm (in)]	32.9 (1.30)	31.8 (1.25)	33.0 (1.30)	40.8 (1.61)	42.7 (1.68)	42.5 (1.67)
C [mm (in)]	267 (10.51)	298 (11.73)	298 (11.73)	379 (14.92)	379 (14.92)	379 (14.92)
T [Nm (lbf in)]	15+5 (133+44)	15+5 (133+44)	15+5 (133+44)	26+4 (230+35)	26+4 (230+35)	26+4 (230+35)
ΔV [cm³/rev] for 1 mm (0.04 in) travel of adjusting screw (pitch 1.5 mm/rev (0.06 in/rev))	3.4	5.5	6.4	8.6	8.7	11.1

Important

When adjusting for the required delivery, ensure that the stroke ring remains held between the two adjusting screws. When delivered, the pump is set to V_{maximum}

APPENDIX B – TECHNICAL DRAWINGS RKP 19 TO 100

9. Compensators

Dual-displacement N1

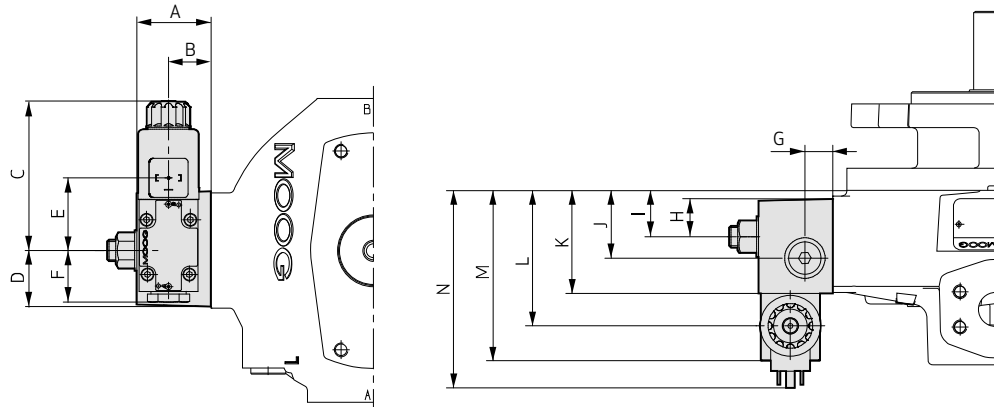

[mm (in)]	RKP 19	RKP 32	RKP 45	RKP 63	RKP 80	RKP 100
A	55 (2.17)	55 (2.17)	55 (2.17)	64 (2.52)	64 (2.52)	64 (2.52)
B	31 (1.22)	31 (1.22)	31 (1.22)	37 (1.46)	37 (1.46)	37 (1.46)
C	111 (4.37)	111 (4.37)	111 (4.37)	111 (4.37)	111 (4.37)	111 (4.37)
D	41 (1.61)	41 (1.61)	41 (1.61)	53 (2.09)	53 (2.09)	53 (2.09)
E	54 (2.13)	54 (2.13)	54 (2.13)	54 (2.13)	54 (2.13)	54 (2.13)
F	38 (1.50)	38 (1.50)	38 (1.50)	38 (1.50)	38 (1.50)	38 (1.50)
G	21 (0.83)	21 (0.83)	21 (0.83)	27 (1.06)	27 (1.06)	27 (1.06)
H	28 (1.10)	28 (1.10)	28 (1.10)	38 (1.50)	38 (1.50)	38 (1.50)
I	28 (1.10)	34 (1.34)	34 (1.34)	42 (1.65)	42 (1.65)	42 (1.65)
J	44 (1.73)	50 (1.97)	50 (1.97)	68 (2.68)	68 (2.68)	68 (2.68)
K	70 (2.76)	76 (2.99)	76 (2.99)	101 (3.98)	101 (3.98)	101 (3.98)
L	94 (3.70)	100 (3.94)	100 (3.94)	125 (4.92)	125 (4.92)	125 (4.92)
M	120 (4.72)	126 (4.96)	126 (4.96)	151 (5.94)	151 (5.94)	151 (5.94)
N	140 (5.51)	146 (5.75)	146 (5.75)	171 (6.73)	171 (6.73)	171 (6.73)

APPENDIX B – TECHNICAL DRAWINGS RKP 19 TO 100

9. Compensators

Dual-displacement N1

Illustrated setting:

Adjusting screw V_{maximum} = 100 % displacement volume
 Adjusting screw V_{minimum} = 50 % displacement volume

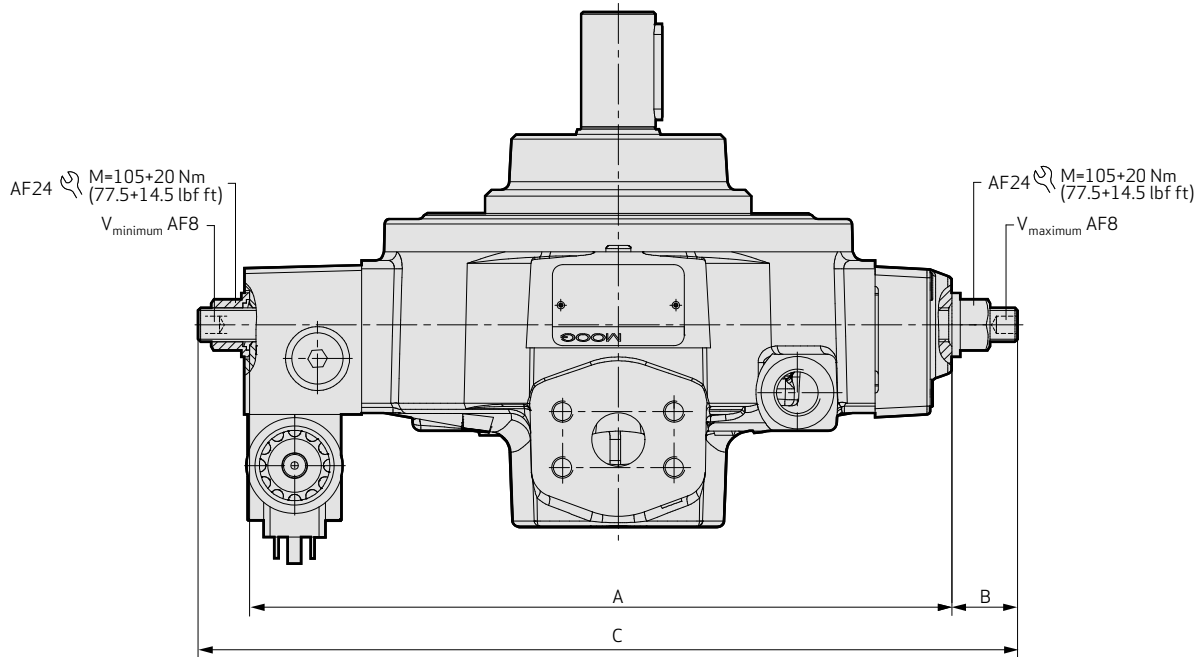

	RKP 19	RKP 32	RKP 45	RKP 63	RKP 80	RKP 100
A [mm (in)]	301 (11.85)	329 (12.95)	329 (12.95)	421 (16.95)	421 (16.95)	421 (16.95)
B [mm (in)]	29 (1.14)	30 (1.18)	31 (1.22)	38 (1.50)	40 (1.57)	40 (1.57)
C [mm (in)]	357 (14.06)	384 (15.12)	384 (15.12)	481 (18.94)	485 (19.09)	485 (19.09)
ΔV [cm³/rev] for 1 mm (0.04 in) travel of adjusting screw (pitch 1.5 mm/rev (0.06 in/rev))	3.4	5.5	6.4	8.6	8.7	11.1

APPENDIX C – TECHNICAL DRAWINGS RKP 140 TO 250

1. Housings

RKP 140/250 with Flange A7 and Compensator R1

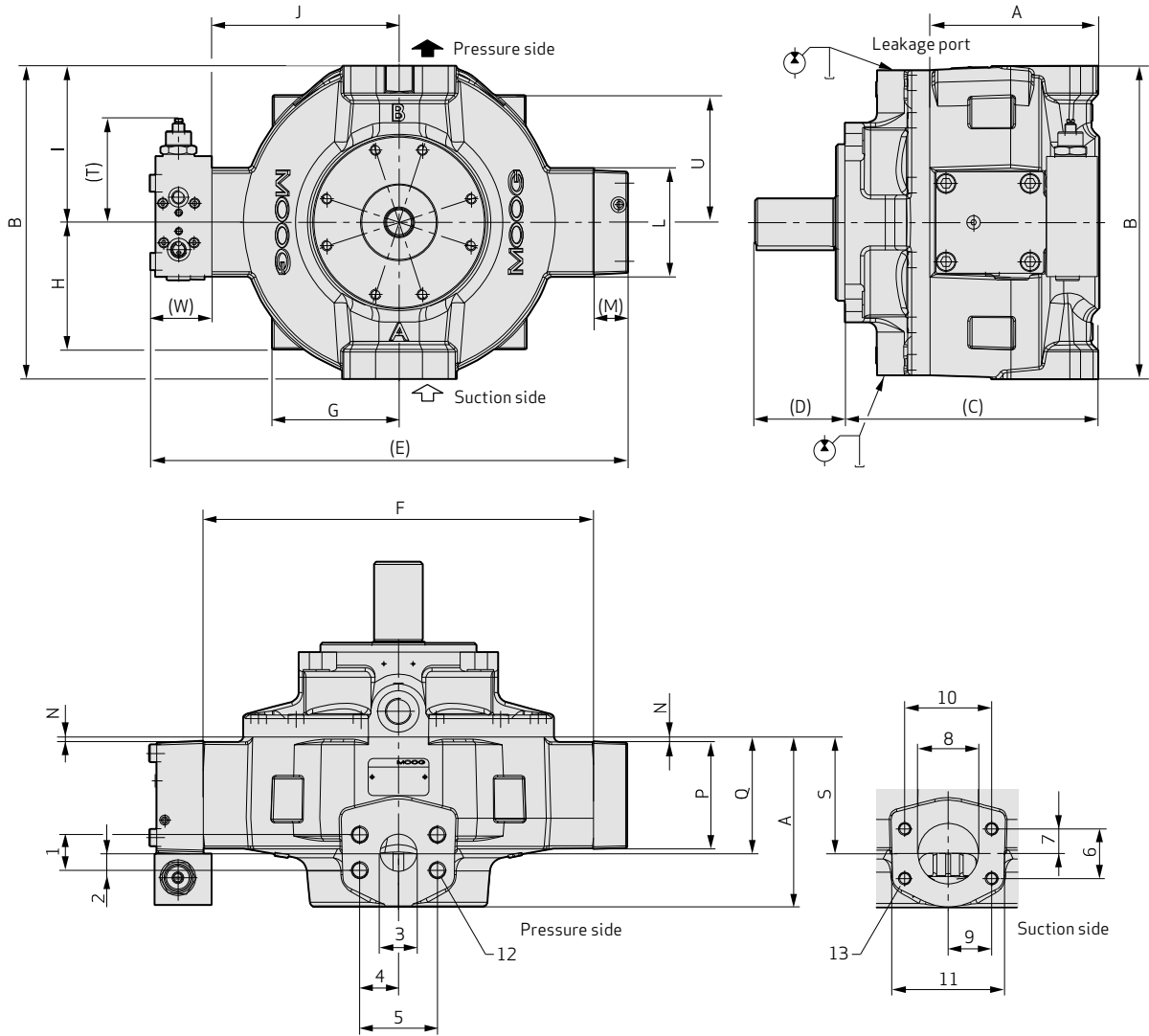

APPENDIX C – TECHNICAL DRAWINGS RKP 140 TO 250

1. Housings

[mm (in)]	RKP 140	RKP 250
A	173.5 (6.83)	240.0 (9.45)
B	320.0 (12.6)	422.0 (16.61)
(C)¹⁾	260.3 (10.25)	340.0 (13.39)
(D)¹⁾	92.4 (3.64)	115.0 (4.53)
(E)²⁾	483.2 (19.02)	670.0 (26.38)
F	398.4 (15.69)	514.0 (20.24)
G	130.0 (5.12)	-
H	130.0 (5.12)	-
I	160.0 (6.30)	211.0 (8.31)
J	199.2 (7.84)	257.0 (10.12)
K	-	-
L	112.0 (4.41)	163.5 (6.44)
(M)²⁾	34.8 (1.37)	74.5 (2.93)
N	5.0 (0.20)	4.0 (0.16)
O	-	-
P	109.4 (4.31)	147.5 (5.81)
Q	118.0 (4.65)	149.0 (5.87)
R	-	-
S	118.0 (4.65)	168.0 (6.61)
(T)²⁾	105.6 (4.16)	83.3 (3.28)
U	130.0 (5.12)	-
V	-	-
(W)²⁾	63.0 (2.48)	81.5 (3.21)
1	36.5 (1.44)	36.5 (1.44)
2	18.25 (0.72)	18.25 (0.72)
3	38.0 (1.50)	38.0 (1.50)
Pressure port	SAE 1 1/2" – 6,000 psi	SAE 1 1/2" – 6,000 psi
4	39.65 (1.56)	39.65 (1.56)
5	79.3 (3.12)	79.3 (3.12)
6	50.8 (2.00)	61.9 (2.44)
7	25.4 (1.00)	30.95 (1.22)
8	62.0 (2.44)	74.0 (2.91)
Suction port	SAE 2 1/2" – 3,000 psi	SAE 3" – 3,000 psi
9	44.45 (1.75)	53.2 (2.09)
10	88.9 (3.5)	106.4 (4.19)
11	115.0 (4.53)	140.0 (5.51)
12	M16 – 25 (1.00) deep	M16 – 25 (1.00) deep
13	M12 – 22 (0.87) deep	M16 – 25 (1.00) deep

¹⁾ Value for flange A7

²⁾ Value for compensators F and R without maximum flow limiter

APPENDIX C – TECHNICAL DRAWINGS RKP 140 TO 250

2. Drive Flange A7

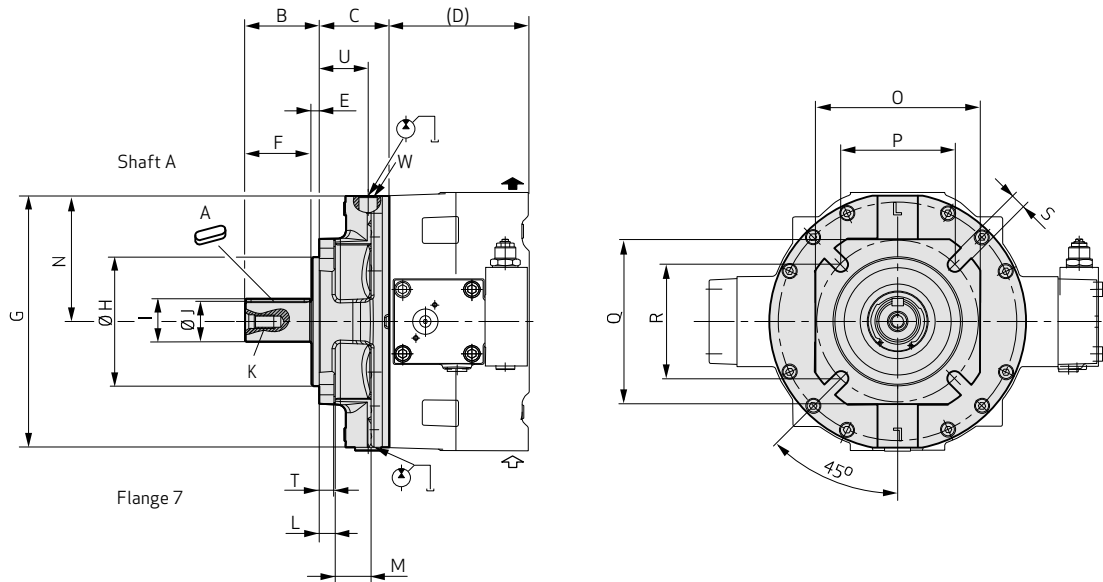

Key to DIN 6885
 ISO mounting flange to ISO 3019-2 (metric dimensions)

[mm (in)]	RKP 140	RKP 250
A	A14 x 9 x 80 DIN 6885	A18 x 11 x 100 DIN 6885
B	92.4 (3.64)	115.0 (4.53)
C	86.8 (3.42)	100.0 (3.94)
D	173.5 (6.83)	240.0 (9.45)
E	9.3 (0.37)	9.40 (0.37)
F	82.0 (3.23)	105.0 (4.13)
G	312.0 (12.28)	418.0 (16.46)
H	160 -0.043/-0.106 (6.30 -0.00169/-0.00417)	200 0.000/-0.063 (6.30 0.00000/-0.00248)
I	53.5 (2.11)	64.0 (2.52)
J	50.0 -0.018/-0.002 (1.97 -0.00071/-0.00008)	60.0 +0.030/+0.011 (2.36 +0.00118/+0.00043)
K (thread drilling)	M16 - 36 (1.42) deep	M20 - 42 (1.65) deep
L	20.0 (0.79)	26.0 (1.02)
M	44.2 (1.74)	43.0 (1.69)
N	155.5 (6.12)	209.0 (8.23)
O	204.0 (8.03)	258.0 (10.16)
P	141.4 (5.57)	176.8 (6.96)
Q	204.0 (8.03)	258.0 (10.16)
R	141.4 (5.57)	176.8 (6.96)
S	18.0 (0.71)	22.0 (0.87)
T	18.0 (0.71)	25.0 (0.98)
U	60.7 (2.39)	64.9 (2.56)
W	M26 x 1.5 - 17 (0.67) deep	M42 x 2 - 20 (0.79) deep Port L1 must be used for connection of drain line Port L2 must be used for connection of flushing line

APPENDIX C – TECHNICAL DRAWINGS RKP 140 TO 250

3. Drive Flange B7

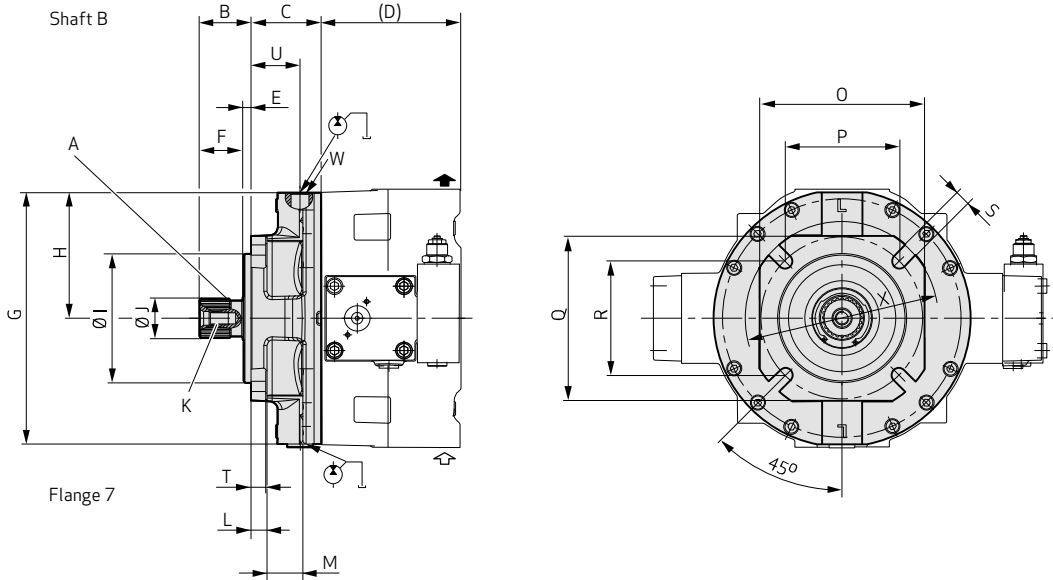

Involute spline to DIN 5480 (obligatory with multiple arrangement of RKP and SAE-B)
 ISO mounting flange to ISO 3019-2 (metric dimensions)

[mm (in)]	RKP 140	RKP 250
A	W50 x 2 x 24 x 9g to DIN 5480	W60 x 2 x 28 x 9g to DIN 5480
B	64.4 (5.4)	80.0 (3.15)
C	86.8 (3.42)	100.0 (3.94)
D	173.5 (6.83)	240.0 (9.45)
E	9.3 (0.37)	9.40 (0.37)
F	54.0 (2.13)	70.0 (2.76)
G	312.0 (12.28)	418.0 (16.46)
H	155.5 (6.12)	209.0 (8.23)
I	160 -0.043/-0.106 (6.30 -0.00169/-0.00417)	200 0.000/-0.063 (6.30 0.00000/-0.00248)
J	49.6 0.000/-0.160 (1.95 0.00000/-0.00630)	59.6 0.000/-0.190 (2.35 0.00000/-0.00748)
K (thread drilling)	M16 - 36 (1.42) deep	M20 - 42 (1.65) deep
L	20.0 (0.79)	26.0 (1.02)
M	44.2 (1.74)	43.0 (1.69)
O	204.0 (8.03)	258.0 (10.16)
P	141.4 (5.57)	176.8 (6.96)
Q	204.0 (8.03)	258.0 (10.16)
R	141.4 (5.57)	176.8 (6.96)
S	18.0 (0.71)	22.0 (0.87)
T	18.0 (0.71)	25.0 (0.98)
U	60.7 (2.39)	64.9 (2.56)
W	M26 x 1.5 - 17 (0.67) deep	M42 x 2 - 20 (0.79) deep Port L1 must be used for connection of drain line Port L2 must be used for connection of flushing line

APPENDIX C – TECHNICAL DRAWINGS RKP 140 TO 250

4. Drive Flange C3

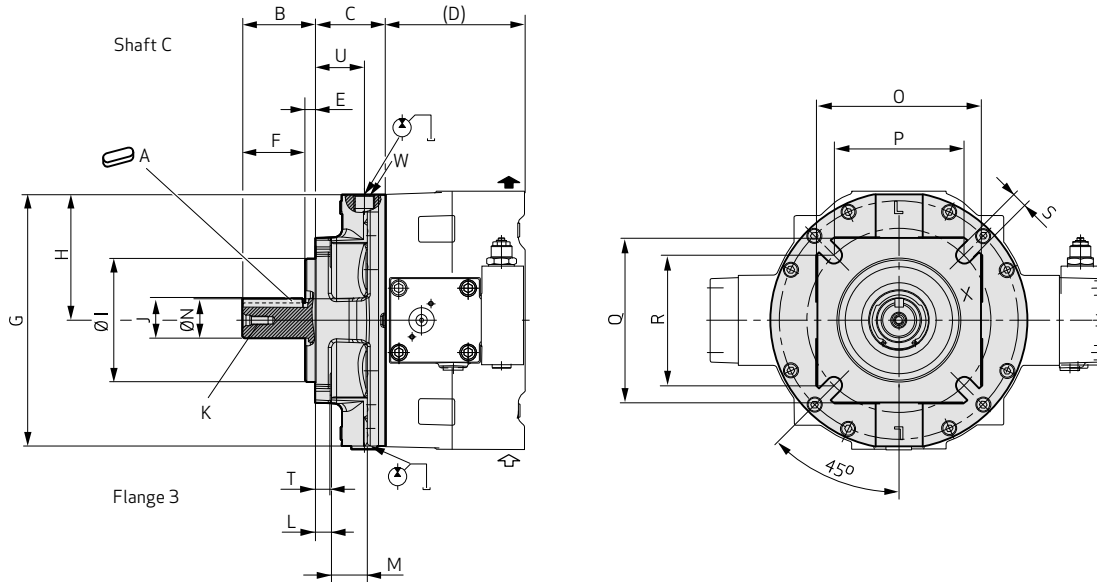

Key to SAE standard
 SAE mounting flange to ISO 3019-1 (imperial dimensions)

[mm (in)]	RKP 140	RKP 250
A	11.11 x 11.11 x 75 (7/16" x 7/16" x 2.95)	12.7 x 12.7 x 75 (1/2" x 1/2" x 2.95)
B	90.4 (3.56)	97.5 (3.84)
C	86.8 (3.42)	100.0 (3.94)
D	173.5 (6.83)	240.0 (9.45)
E	12.7 (0.5)	15.8 (0.62)
F	82.0 (3.23)	89.5 (3.52)
G	312.0 (12.28)	418.0 (16.46)
H	155.5 (6.12)	209.0 (8.23)
I	152.4 0.00/-0.05 (6.00 0.000/-0.002)	165.1 0.00/-0.05 (6.50 0.000/-0.002)
J	49.3 (1.94)	56.4 (2.22)
K (thread drilling)	7/16"-14 UNC-2B - 32 (1.26) deep	5/8-11 UNC-2B - 40 (1.57) deep
L	20.0 (0.79)	26.0 (1.02)
M	44.2 (1.74)	43.0 (1.69)
N	44.45 0.00/-0.05 (1.75 0.000/-0.002)	50.8 0.00/-0.05 (2.00 0.000/-0.002)
O	204.0 (8.03)	287.0 (11.30)
P	161.6 (6.36)	224.5 (8.84)
Q	204.0 (8.03)	287.0 (11.30)
R	161.6 (6.36)	224.5 (8.84)
S	20.5 (0.81)	20.6 (0.81)
T	18.0 (0.71)	25.0 (0.98)
U	60.7 (2.39)	64.9 (2.56)
W	M26 x 1.5 - 17 (0.67) deep	M42 x 2 - 20 (0.79) deep Port L1 must be used for connection of drain line Port L2 must be used for connection of flushing line

APPENDIX C – TECHNICAL DRAWINGS RKP 140 TO 250

5. Drive Flange D3

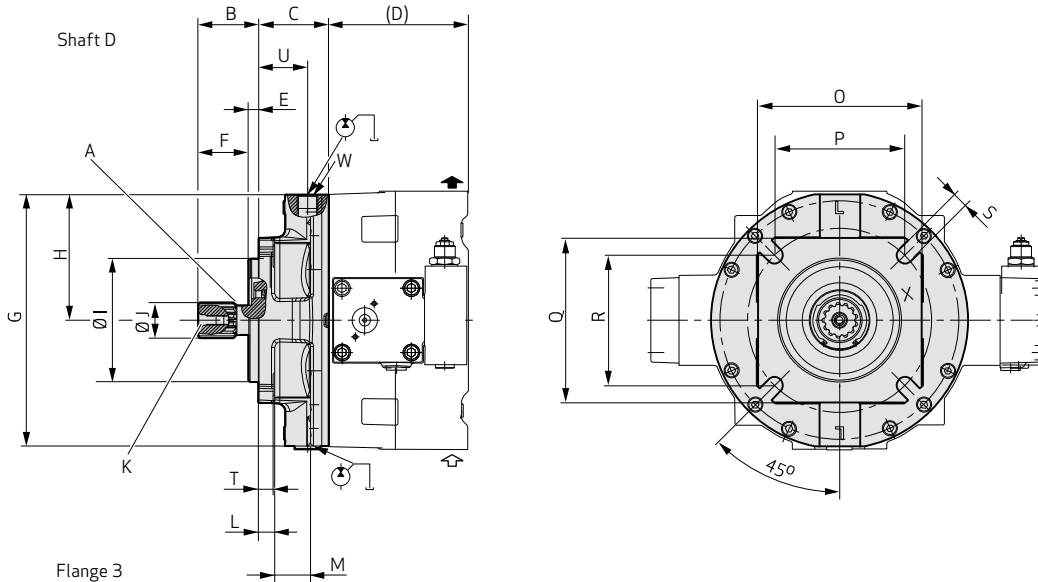

Involute spline to SAE 744 C, (obligatory with multiple arrangement of RKP and SAE-B)
 SAE mounting flange to ISO 3019-1 (imperial dimensions)

[mm (in)]	RKP 140	RKP 250
A	ANSI B92.1 - 1970 class 5 30° PA, 13 T, 8/16 DP, flat root, side fit	ANSI B92.1 - 1970 class 5 30° PA, 15 T, 8/16 DP, flat root, side fit
B	75.4 (2.97)	88.0 (3.46)
C	86.8 (3.42)	100.0 (3.94)
D	173.5 (6.83)	240.0 (9.45)
E	12.7 (0.5)	15.8 (0.62)
F	67.0 (2.64)	80.0 (3.15)
G	312.0 (12.28)	418.0 (16.46)
H	155.5 (6.12)	209.0 (8.23)
I	152.4 0.00/-0.05 (6.00 0.000/-0.002)	165.1 0.00/-0.05 (6.50 0.000/-0.002)
J	44.45 0.00/-0.15 (1.75 0.00/-0.06)	50.8 0.00/-0.19 (2 0.0000/-0.0075)
K (thread drilling)	7/16"-14 UNC-2B - 32 (1.26) deep	5/8-11 UNC-2B - 40 (1.57) deep
L	20.0 (0.79)	26.0 (1.02)
M	44.2 (1.74)	43.0 (1.69)
O	204.0 (8.03)	287.0 (11.30)
P	161.6 (6.36)	224.5 (8.84)
Q	204.0 (8.03)	287.0 (11.30)
R	161.6 (6.36)	224.5 (8.84)
S	20.5 (0.81)	20.6 (0.81)
T	18.0 (0.71)	25.0 (0.98)
U	60.7 (2.39)	64.9 (2.56)
W	M26 x 1.5 - 17 (0.67) deep	M42 x 2 - 20 (0.79) deep Port L1 must be used for connection of drain line Port L2 must be used for connection of flushing line

APPENDIX C – TECHNICAL DRAWINGS RKP 140 TO 250

6. Intermediate Drive Flange RKP 140 - 140 and 250 - 250

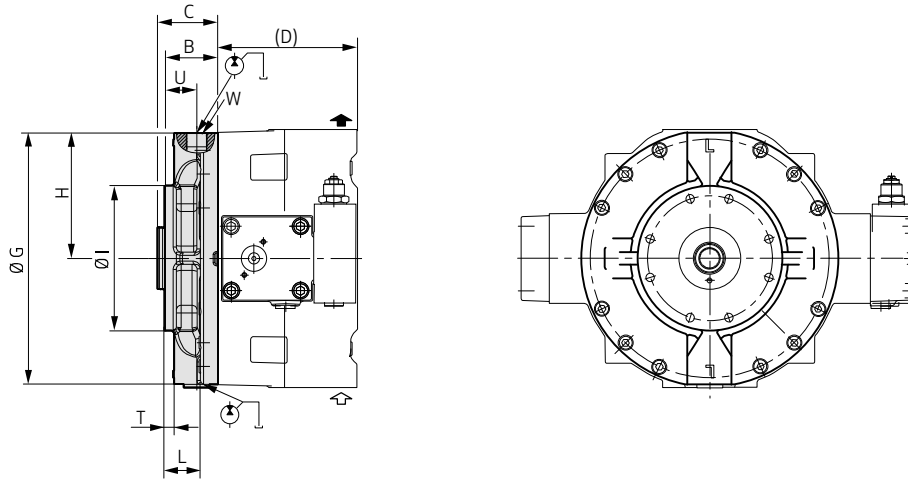

[mm (in)]	RKP 140	RKP 250
B	65.8 (2.59)	100.0 (3.94)
C	65.8 (2.59)	109.7 (4.32)
D	173.5 (6.83)	240.0 (9.45)
G	312.0 (12.28)	418.0 (16.46)
H	155.5 (6.12)	209.0 (8.23)
I	180.0 (7.09)	290.0 (11.42)
L	44.2 (1.74)	68.9 (2.71)
T	11.7 (0.46)	30.9 (1.22)
U	39.7 (1.56)	64.9 (2.58)
W	M26 x 1.5 - 17 (0.67) deep	M42 x 2 - 20 (0.79) deep Port L1 must be used for connection of drain line Port L2 must be used for connection of flushing line

APPENDIX C – TECHNICAL DRAWINGS RKP 140 TO 250

7. Compensators

Adjustable Pressure Compensator F1, F2

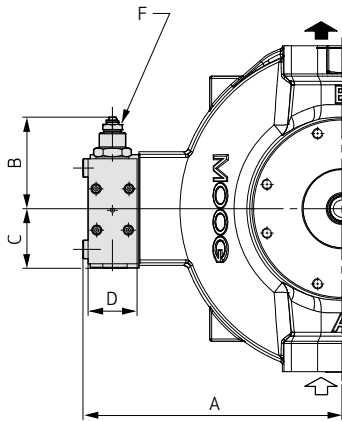

[mm (in)]	RKP 140	RKP 250
A	254.1 (10.0)	338.5 (13.33)
B	90.0 (3.54)	88.5 (3.48)
C	58.5 (2.3)	93.0 (3.66)
D	48.0 (1.89)	58.0 (2.28)
E	171.5 (6.75)	221.0 (8.7)
F	Width across flats AF	
	19 (0.75)	19 (0.75)
	Tightening torque	
	10 +5 Nm (89 +45 lbf in)	10 +5 Nm (89 +45 lbf in)

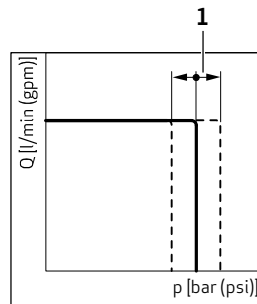
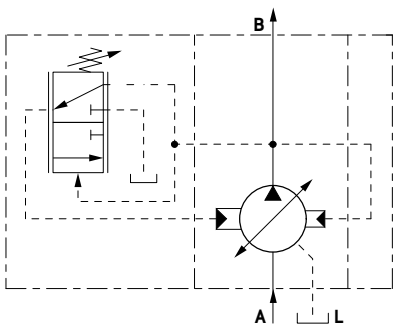
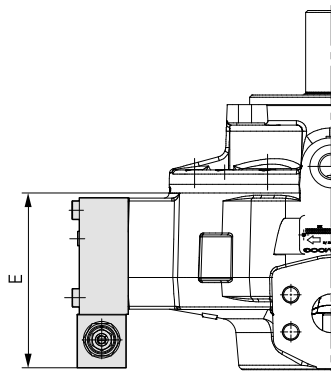

1 Screw adjustment

APPENDIX C – TECHNICAL DRAWINGS RKP 140 TO 250

7. Compensators

Combined Pressure and Flow Compensator “Load Sensing” with P-T Control Notch R1

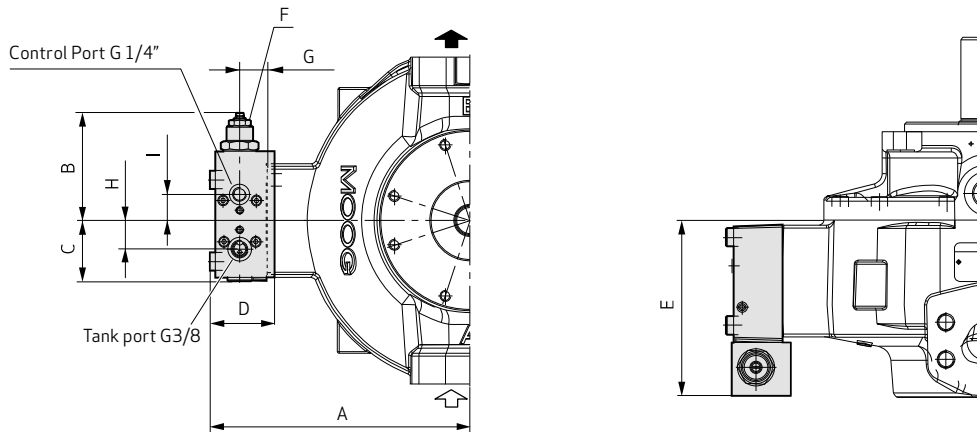

	A	B	C	D	E	F	G	H	I	
[mm (in)]						Width across flats AF	Tightening torque			
RKP 140	254.1 (10.0)	105.6 (4.16)	59.4 (2.34)	50.0 (1.97)	171.5 (6.75)	19 (0.75)	10 +5 Nm (89 +45 lbf in)	26.0 (1.02)	28 (1.10)	47 (1.85)
RKP 250	338.5 (13.33)	83.3 (3.28)	82.0 (3.23)	81.5 (3.21)	204.0 (8.03)	19 (0.75)	10 +5 Nm (89 +45 lbf in)	46.0 (1.81)	25.6 (1.01)	6,6 (0,26)

Caution!

The tank line of the compensator must not be combined with the drain line of the pump.

Following circuits are illustrated:

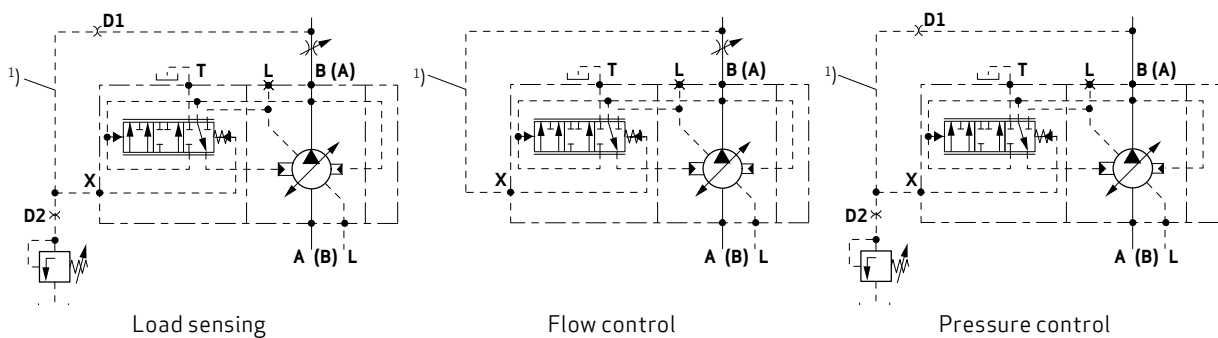

¹⁾ Hose recommendation for control line, see table below

		D1 [mm (in)]	D2 [mm (in)]
RKP 140/250	DN 8	0.8 (0.03)	1.1 (0.04)
Length = 800 mm (31.50 in)			

Notes on Multiple Pump Circuits

In the case of multiple pumps, which deliver into one circuit, the P-T control notch may only be activated for the compensator of the first pump by connecting the T-connection to the tank. The T-connection of the compensators of add-on pumps must be plugged.

APPENDIX C – TECHNICAL DRAWINGS RKP 140 TO 250

7. Compensators

Electro-Hydraulic Control with Digital On-Board Electronics D1 to D8

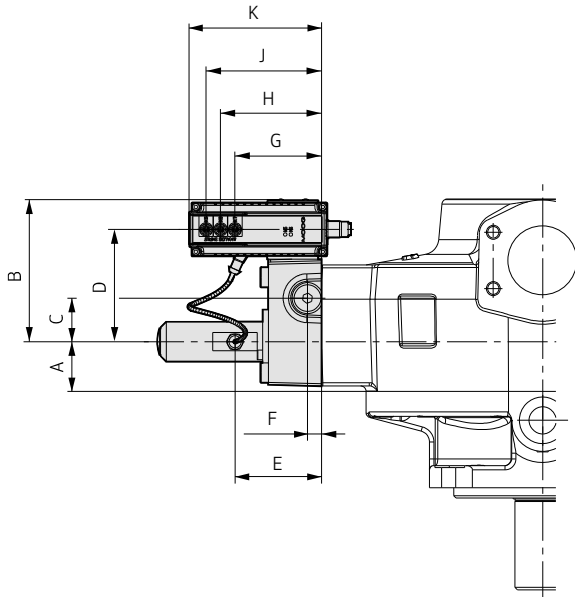

[mm (in)]	RKP 140	RKP 250
A	44.75 (1.76)	61.0 (2.40)
B	128.2 (5.05)	144.4 (5.69)
C	39.25 (1.55)	35.5 (1.40)
D	101.25 (3.99)	117.5 (4.63)
E	78.0 (3.07)	110.0 (4.33)
F	12.7 (0.50)	32.0 (1.26)
G	78.0 (3.07)	98.1 (3.86)
H	91.0 (3.58)	111.1 (4.37)
J	104.0 (4.09)	124.1 (4.89)
K	119.4 (4.7)	139.4 (5.49)
L	100.5 (3.96)	81.5 (3.21)
M	157.0 (6.18)	176.0 (6.93)
N	57.0 (2.24)	79.0 (3.11)
O	43.5 (1.71)	62.5 (2.46)
P	23.0 (0.91)	43.5 (1.71)
Q	7.0 (0.28)	27.0 (1.06)
R	128.0 (5.04)	147.0 (5.79)
S	107.0 (4.21)	126.0 (4.96)
T	48.5 (1.91)	69.0 (2.72)
U	67.0 (2.64)	87.0 (3.43)
V	74.0 (2.91)	94.0 (3.70)
W	148.0 (5.83)	180.0 (7.09)
X	26.5 (1.04)	26.5 (1.04)
Y	39.25 (1.55)	35.5 (1.4)
Z	106.5 (4.19)	125.2 (4.93)

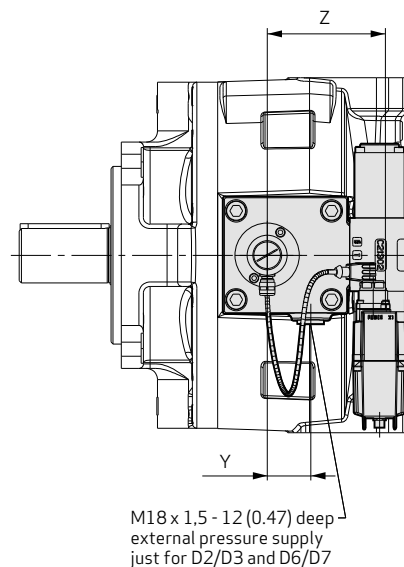
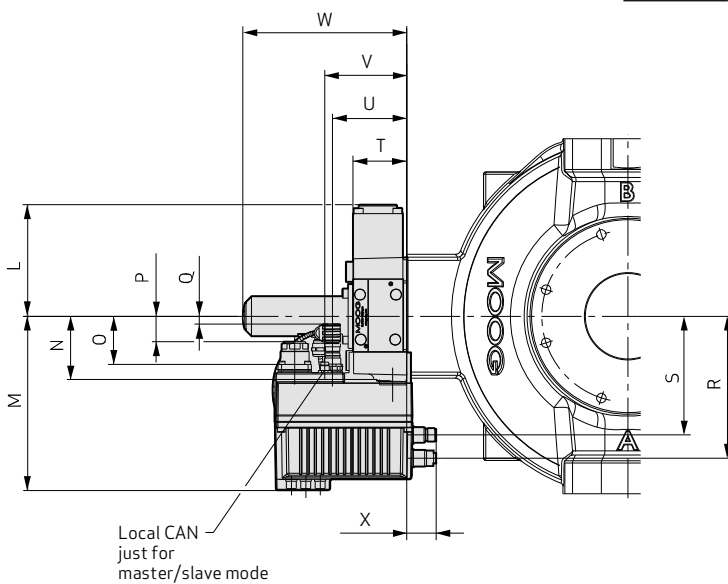

APPENDIX C – TECHNICAL DRAWINGS RKP 140 TO 250

7. Compensators

Constant Horsepower Control S1

RKP 140

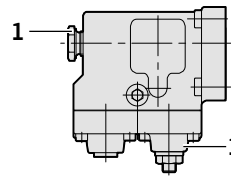
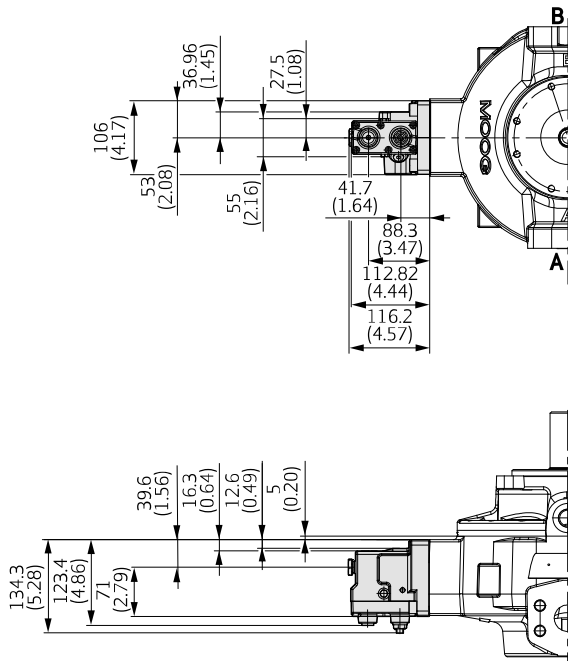

1 Horsepower adjustment (set at factory, do not change)

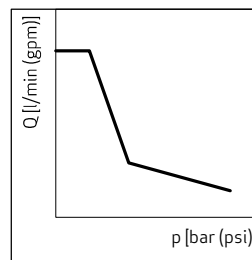
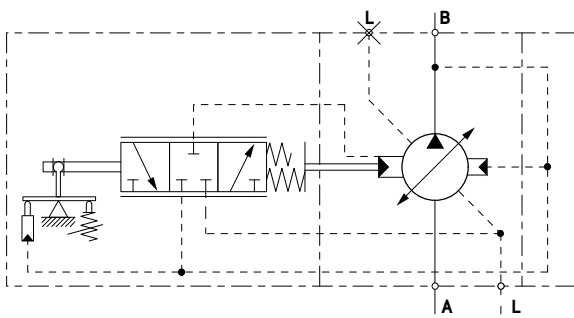

APPENDIX C – TECHNICAL DRAWINGS RKP 140 TO 250

7. Compensators

Constant Horsepower Control with Remote Pressure and Flow Control S2

RKP 140

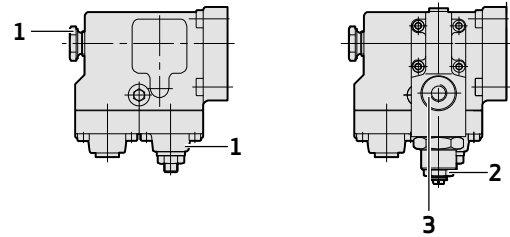
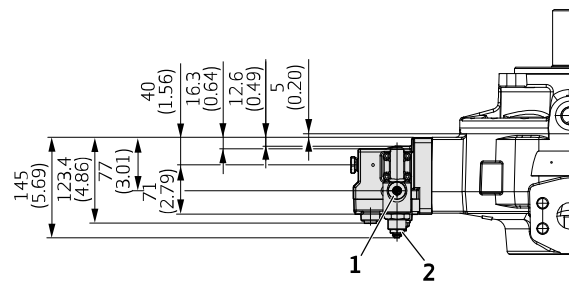
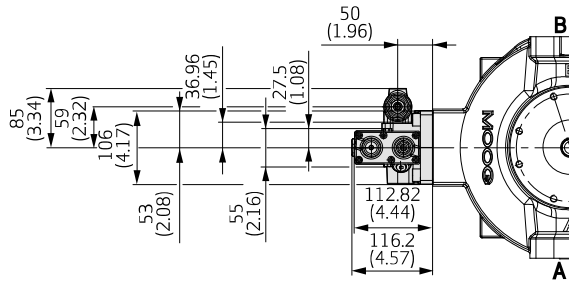

- 1 Horsepower adjustment (set at factory, do not change)
- 2 Set at factory ($\Delta p = 10^{+2}$ bar (145⁺²⁹ psi))
- 3 Control port
For control line information, see H and J controller details.

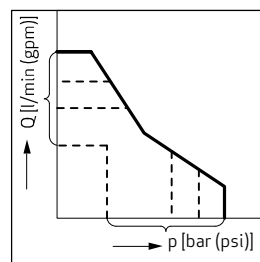
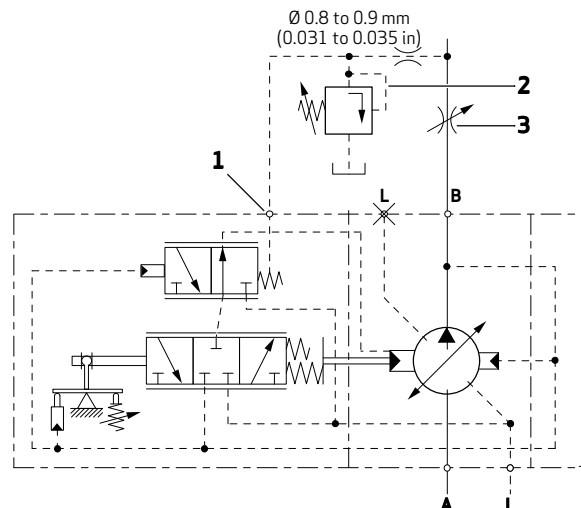

- 1 Control port
- 2 p adjustment
- 3 Q adjustment

APPENDIX C – TECHNICAL DRAWINGS RKP 140 TO 250

7. Compensators

Maximum Flow Limiter Y

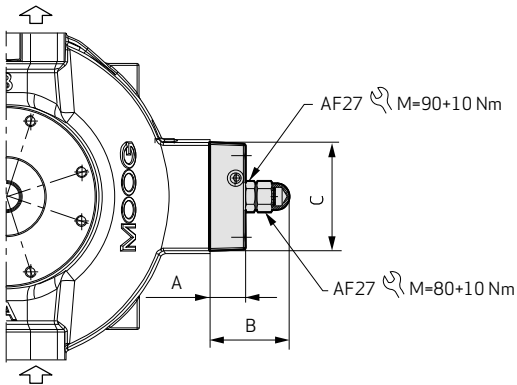

[mm (in)]	RKP 140	RKP 250
A	34.8 (1.37)	70.0 (2.76)
B	78.1 (3.07)	121.5 (4.78)
C	105.9 (4.17)	156.0 (6.14)
D	114.2 (4.5)	156.5 (6.16)

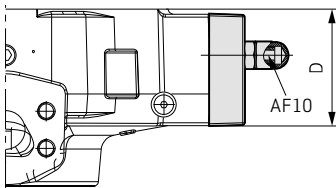

	RKP 140	RKP 250
ΔV [cm ³ /rev] for 1 mm (0.04 in) travel of adjusting screw (pitch 1.5 mm/rev (0.06 in/rev))	11.1	21.9

APPENDIX C – TECHNICAL DRAWINGS RKP 140 TO 250

7. Compensators

Mechanical Stroke Adjustment B, RKP 140

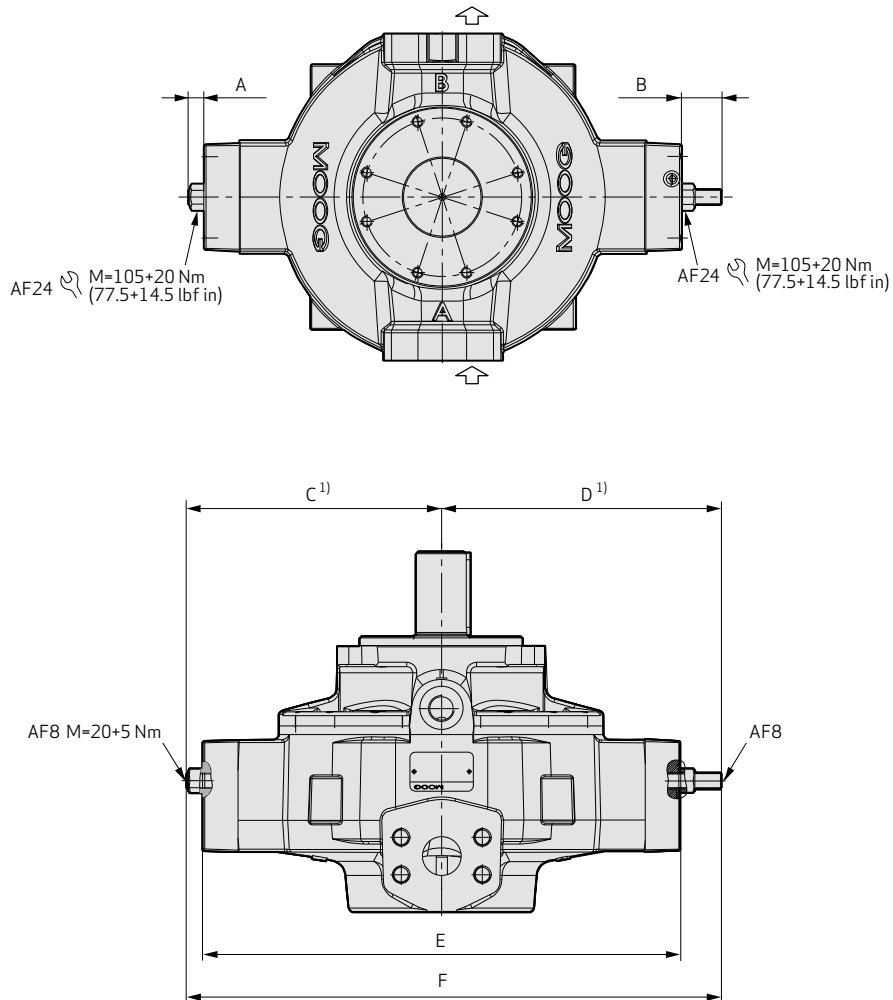

[mm (in)]	RKP 140
A	15.6 (0.61)
B	40.2 (1.58)
C	249.5 (9.82)
D	272.2 (10.72)
E	468.0 (18.43)
F	523.8 (20.62)

	RKP 140
ΔV [cm ³ /rev] for 1 mm (0.04 in) travel of adjusting screw (pitch 1.5 mm/rev (0.06 in/rev))	11.1

APPENDIX C – TECHNICAL DRAWINGS RKP 140 TO 250

7. Compensators

Mechanical Stroke Adjustment B, RKP 250

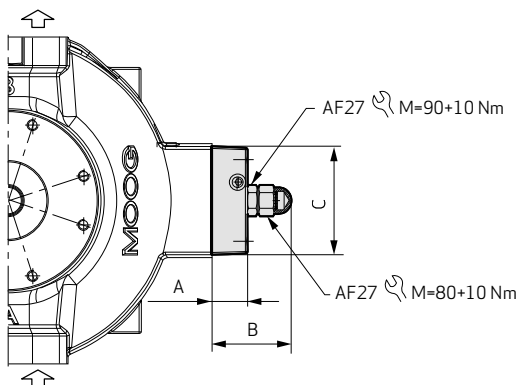

[mm (in)]	RKP 250
A	70.0 (2.76)
B	121.5 (4.78)
C	156.0 (6.14)
D	156.5 (6.16)

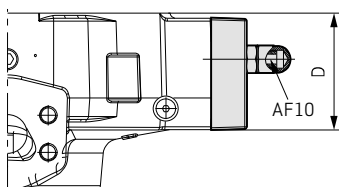

	RKP 250
ΔV [cm ³ /rev] for 1 mm (0.04 in) travel of adjusting screw (pitch 1.5 mm/rev (0.06 in/rev))	21.9

APPENDIX C – TECHNICAL DRAWINGS RKP 140 TO 250

7. Compensators

Dual-displacement N1

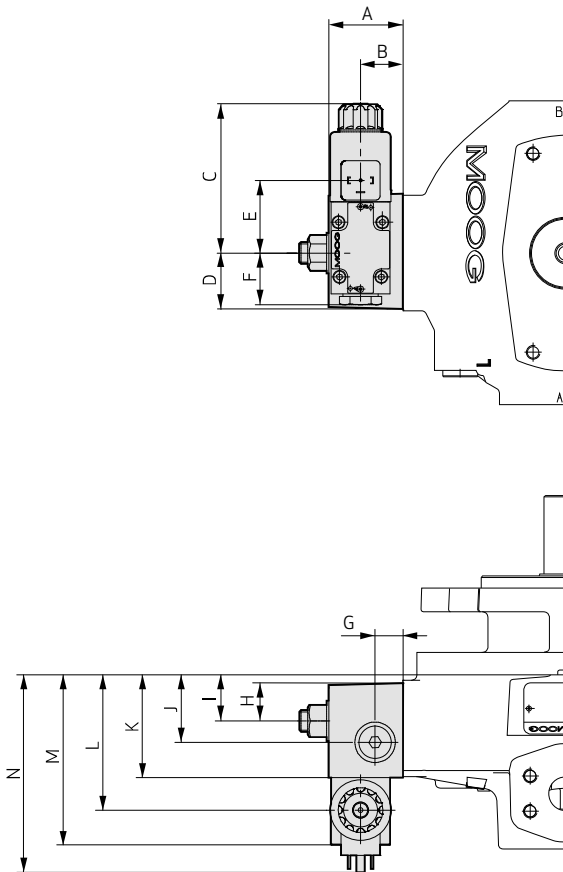

[mm (in)]	RKP 140
A	55 (2.17)
B	26 (1.02)
C	107 (4.21)
D	62 (2.44)
E	51 (2.01)
F	42 (1.65)
G	13 (0.51)
H	40 (1.57)
I	45 (1.77)
J	84 (3.31)
K	119 (4.69)
L	143 (5.63)
M	169 (6.65)
N	189 (7.44)

APPENDIX C – TECHNICAL DRAWINGS RKP 140 TO 250

7. Compensators

Dual-displacement N1

Illustrated setting:

Adjusting screw V_{maximum} = 100 % displacement volume
 Adjusting screw V_{minimum} = 50 % displacement volume

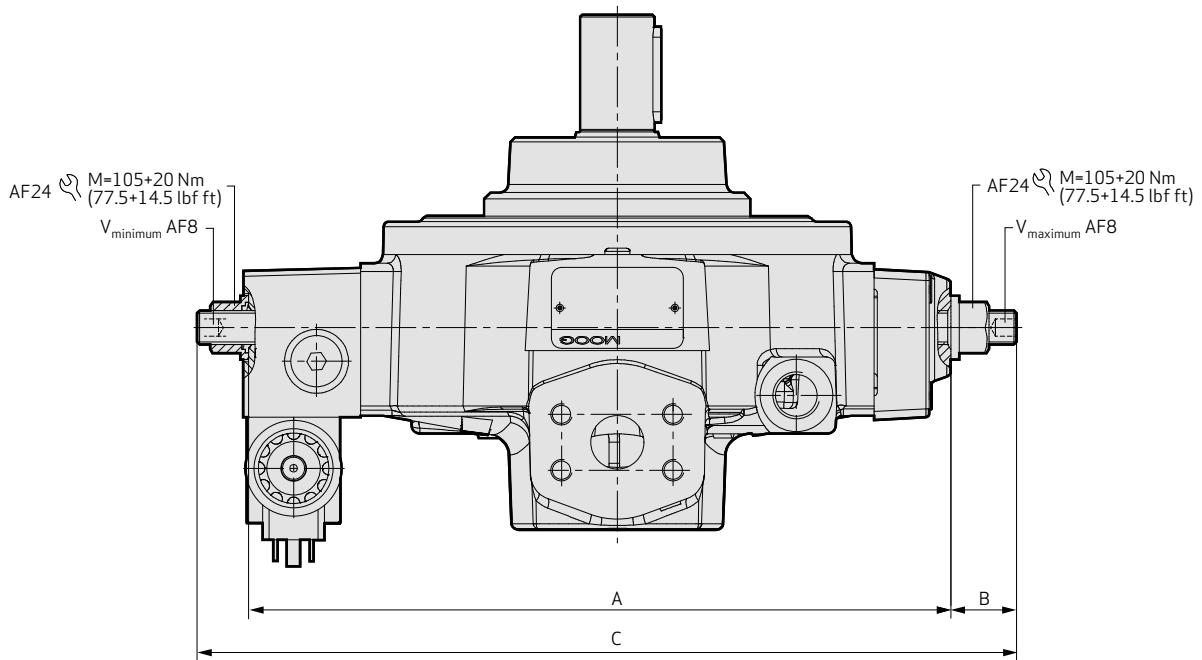

	RKP 140
A [mm (in)]	477 (18.78)
B [mm (in)]	35 (1.38)
C [mm (in)]	543 (21.38)
ΔV [cm³/rev] for 1 mm (0.04 in) travel of adjusting screw (pitch 1.5 mm/rev (0.06 in/rev))	11.1

APPENDIX D - EXTERNAL GEAR PUMP

1. SAE-A, Type W900

Pump operation with HFC fluid permitted for 50 bar (725 psi) permanent pressure. Mounting pattern according to COD 150, shaft design FA.

SAE-A Suction Side, Side View

SAE-A Pressure Side, Side View

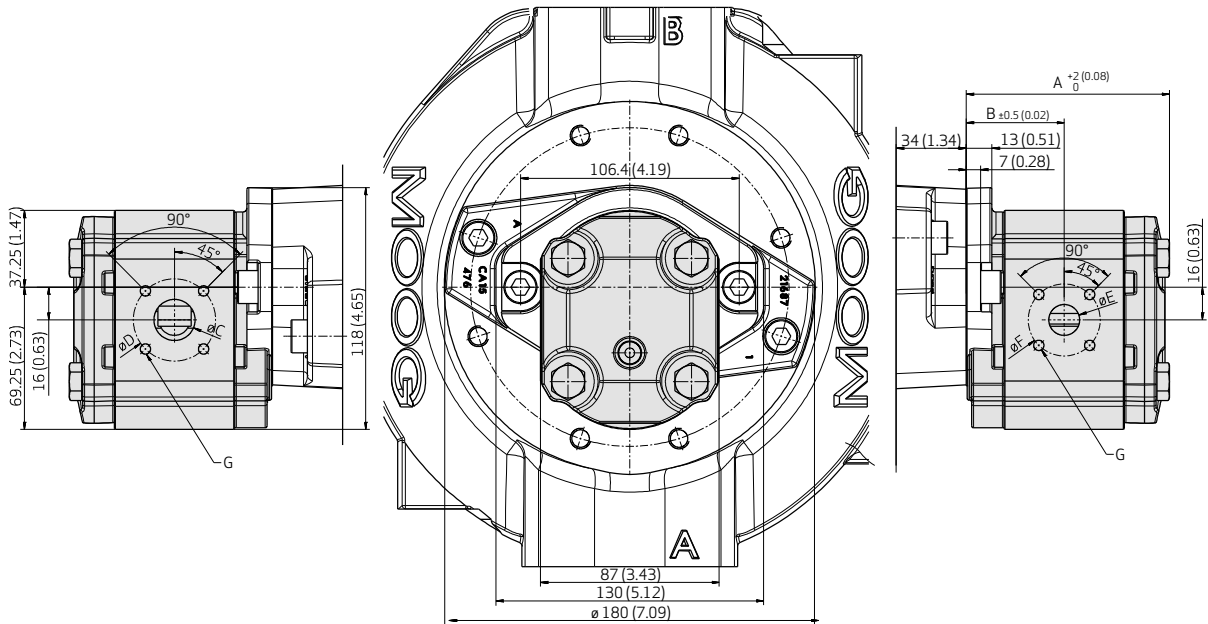

Part number ¹⁾	Rotation	V [cm ³ /rev]	p [bar (psi)]	N _{maximum} [min ⁻¹]	A [mm (in)]	B [mm (in)]	C [mm (in)]	D [mm (in)]	E [mm (in)]	F [mm (in)]	G [mm (in)] deep
CA36039-001	R	5	276 (4,003)	4,000	90.10 (3.55)	43.30 (1.70)	20.00 (0.79)	40.00 (1.57)	15.00 (0.59)	35.00 (1.38)	M6 - 13 (0.51)
CA36040-001	L	5	276 (4,003)	4,000	90.10 (3.55)	43.30 (1.70)	20.00 (0.79)	40.00 (1.57)	15.00 (0.59)	35.00 (1.38)	M6 - 13 (0.51)
CA36037-001	R	8	276 (4,003)	4,000	94.60 (3.72)	45.50 (1.79)	20.00 (0.79)	40.00 (1.57)	15.00 (0.59)	35.00 (1.38)	M6 - 13 (0.51)
CA36038-001	L	8	276 (4,003)	4,000	94.60 (3.72)	45.50 (1.79)	20.00 (0.79)	40.00 (1.57)	15.00 (0.59)	35.00 (1.38)	M6 - 13 (0.51)
CA36035-001	R	11	276 (4,003)	3,600	99.00 (3.90)	47.70 (1.88)	20.00 (0.79)	40.00 (1.57)	15.00 (0.59)	35.00 (1.38)	M6 - 13 (0.51)
CA36036-001	L	11	276 (4,003)	3,600	99.00 (3.90)	47.70 (1.88)	20.00 (0.79)	40.00 (1.57)	15.00 (0.59)	35.00 (1.38)	M6 - 13 (0.51)
CA36033-001	R	16	276 (4,003)	3,000	106.40 (4.19)	51.40 (2.02)	20.00 (0.79)	40.00 (1.57)	15.00 (0.59)	35.00 (1.38)	M6 - 13 (0.51)

¹⁾ Gear pump with different displacement and multiple pumps on request.

APPENDIX D - EXTERNAL GEAR PUMP

1. SAE-A, Type W900

Part number ¹⁾	Rotation	V [cm ³ /rev]	p [bar (psi)]	N _{maximum} [min ⁻¹]	A [mm (in)]	B [mm (in)]	C [mm (in)]	D [mm (in)]	E [mm (in)]	F [mm (in)]	G [mm (in)] deep
CA36034-001	L	16	276 (4,003)	3,000	106.40 (4.19)	51.40 (2.02)	20.00 (0.79)	40.00 (1.57)	15.00 (0.59)	35.00 (1.38)	M6 - 13 (0.51)
CA36031-001	R	19	265 (3,844)	3,000	110.90 (4.37)	53.70 (2.11)	20.00 (0.79)	40.00 (1.57)	15.00 (0.59)	35.00 (1.38)	M6 - 13 (0.51)
CA36032-001	L	19	265 (3,844)	3,000	110.90 (4.37)	53.70 (2.11)	20.00 (0.79)	40.00 (1.57)	15.00 (0.59)	35.00 (1.38)	M6 - 13 (0.51)
CA36029-001	R	23	221 (3,205)	2,800	116.80 (4.60)	56.60 (2.23)	20.00 (0.79)	40.00 (1.57)	15.00 (0.59)	35.00 (1.38)	M6 - 13 (0.51)
CA36030-001	L	23	221 (3,205)	2,800	116.80 (4.60)	56.60 (2.23)	20.00 (0.79)	40.00 (1.57)	15.00 (0.59)	35.00 (1.38)	M6 - 13 (0.51)
CA77100-001	L	31	165 (2,393)	2,500	128.70 (5.07)	62.60 (2.46)	26.00 (1.02)	55.00 (2.17)	18.00 (0.71)	55.00 (2.17)	M8 - 13 (0.51)
CA77101-001	R	31	165 (2,393)	2,500	128.70 (5.07)	62.60 (2.46)	26.00 (1.02)	55.00 (2.17)	18.00 (0.71)	55.00 (2.17)	M8 - 13 (0.51)

¹⁾ Gear pump with different displacement and multiple pumps on request.

APPENDIX D - EXTERNAL GEAR PUMP

2. SAE-B, Type W900

Mounting pattern according to COD 151, shaft design KA.

SAE-B Suction Side, Side View

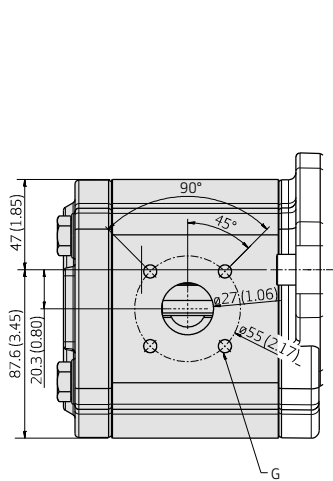

SAE-B Pressure Side, Side View

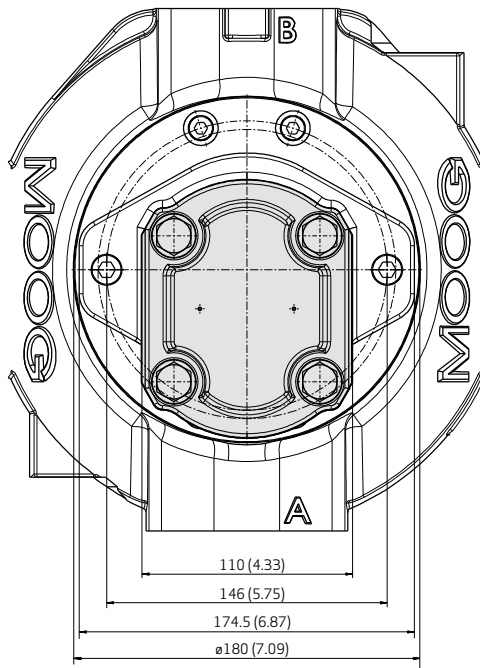
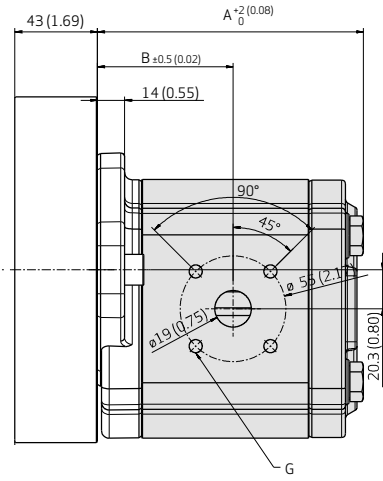

Part number ¹⁾	Rotation	V [cm ³ /rev]	p [bar (psi)]	N _{Maximum} [min ⁻¹]	A [mm (in)]	B [mm (in)]	G [mm (in)] deep
CA36045-001	R	33	276 (4,003)	3,000	138.60 (5.46)	70.60 (2.78)	M8 - 13 (0.51)
CA36044-001	L	33	276 (4,003)	3,000	138.60 (5.46)	70.60 (2.78)	M8 - 13 (0.51)
CA36043-001	R	44	221 (3,205)	2,700	150.00 (5.91)	76.30 (3.00)	M8 - 13 (0.51)
CA36042-001	L	44	221 (3,205)	2,700	150.00 (5.91)	76.30 (3.00)	M8 - 13 (0.51)
CA45165-001	R	50	200 (2,900)	2,300	182.20 (7.17)	105.40 (4.15)	M8 - 13 (0.51)
CA45164-001	L	50	200 (2,900)	2,300	182.20 (7.17)	105.40 (4.15)	M8 - 13 (0.51)

¹⁾ Gear pump with different displacement and multiple pumps on request.

ABOUT MOOG

Moog Inc. is a worldwide designer, manufacturer and integrator of precision control components and systems. Moog's Industrial Group designs and manufactures high performance motion control solutions combining electric, hydraulic, and hybrid technologies with expert consultative support in a range of applications including energy production and generation machinery, industrial production machinery and simulation and test equipment. We help performance-driven companies design and develop their next-generation machines. Moog Industrial Group, with fiscal year 2013 sales of USD 592 million and over 40 locations worldwide, is part of Moog Inc. (NYSE: MOG.A and MOG.B) which has sales of USD 2.61 billion.

Moog maintains facilities in 26 countries around the globe. This vast scope ensures that our engineers remain close to the needs of machine builders and provide flexible design solutions and technical expertise tailored to our customers' toughest challenges.

Moog experts work in close collaboration with machine builders and application engineers to design motion control systems for greater productivity, higher reliability, superior connectivity, less costly maintenance and more effective operations. Our regional presence, industry knowledge and design flexibility ensures Moog motion control solutions are tailored to their environment – from meeting operating regulations and performance standards, to taking machine performance to a higher level.

Products

At the heart of every Moog solution is an array of products engineered for precision, high performance and reliability. For more than six decades, Moog products have been specified for critical machine applications.

Some are developed specifically for unique operating environments. Others are standard equipment on machines across many industries. All are continuously improved to take advantage of the latest technology breakthroughs and advancements.

Moog products include:

- Servo Valves and Proportional Valves
- Servo Motors and Servo Drives
- Motion Controllers and Software
- Radial Piston Pumps
- Actuators
- Integrated Hydraulic Manifold Systems and Cartridge Valves
- Slip Rings
- Motion Bases



Servo Drives



Servo Motors



Servo Valves



Radial Piston Pumps

ABOUT MOOG

Hydraulic Solutions

Since Bill Moog invented the first commercially viable Servo Valve in 1951, Moog has set the standard for world-class hydraulic technology. Today, Moog products are used in a variety of applications - providing high power, enhanced productivity and ever better performance for some of the worlds most demanding applications.

Electric Solutions

Clean operation, low noise generation, less maintenance and reduced power consumption make Moog electric solutions ideal for applications worldwide. Moog is the ideal partner for applications where transitioning technologies requires special expertise.

Hybrid Solutions

By incorporating the advantages of existing hydraulic and electric technologies - including modular flexibility, increased efficiency and cleanliness – into innovative hybrid solutions, Moog offers new performance potential in specialized applications.



Moog Global Support

Moog Global Support is our promise to offer world-class Repair and Maintenance Services delivered expertly by our trained technicians. With the reliability only available from a leading manufacturer with facilities around the world, Moog offers you service and expertise you can count on to keep your equipment operating as it should.

This Promise Offers Many Benefits to Our Customers Including:

- Reduce your downtime by keeping critical machines running in peak performance
- Protect your investment by ensuring reliability, versatility and long-life of products
- Better plan your maintenance activities and make systematic upgrades
- Leverage our flexible programs to meet the unique service requirements of your facility

Look to Moog for Global Support Including:

- Repair services using OEM parts are performed by trained technicians to the latest specifications
- Stock management of spare parts and products to prevent unplanned downtime
- Flexible programs, tailored to your needs such as upgrades, preventative maintenance and annual/multi-year contracts
- On-site services bring the expertise to you, providing quicker commissioning, set-up and diagnostics
- Access to reliable services that are guaranteed to offer consistent quality anywhere in the world

For more information on Moog Global Support, visit www.moog.com/industrial/service



CONVERSION TABLE

General Conversion Table

1 bar	=	14.5038 psi (lb/in ²)
1 psi	=	0.06895 bar
1 mm	=	0.0394 in
1 in	=	25.4 mm
1 cm ³	=	0.0610 in ³ = 0.000264 gpm
1 in ³	=	16.3871 cm ³ = 0.004329 gpm
1 l (Liter)	=	0.26417 gal (US) = 61.024 in ³
1 gal (US)	=	3.7854 l (Liter) = 231 in ³
1 kg	=	2.2046 lb
1 lb	=	0.4536 kg
1 Nm	=	8.8507 lbf in
1 lbf in	=	0.1130 Nm
1 kW	=	1.3596 PS = 1.3410 hp (UK)
1 hp (UK)	=	1.0139 PS = 0.7457 kW
+1 °F	=	-17 °C
+1 °C	=	+34 °F
		(°F - 32) x 0.5556 = °C
		(°C / 0.5556) + 32 = °F
0 °F	=	-18 °C
0 °C	=	+32 °F
+100 °F	=	+38 °C
+100 °C	=	+212 °F

Mass Moment of Inertia

1 kg cm ²	=	0.3417 lb in ²
1 lb in ²	=	2.9264 kg cm ²
1 kg cm ²	=	8.85 10 ⁻⁴ lbf in s ²
1 lbf in s ²	=	1,130 kg cm ²

Kinematic Viscosity

1 mm ² /s	=	1 cSt = 0.00155 in ² /s
1 in ² /s	=	645.16 cSt = 645.16 mm ² /s

Calculation of Power Consumption

$$P = \frac{p \times Q}{6 \times \eta}$$

P [kW]

p [bar]

Q [l/min]

η [%]

Example: RKP 63 cm³/rev, 280 bar, 1,450 min⁻¹:

p = 280 bar

Q = (63 x 1.450) = 91.3 l/min

η = 95%

$$P = 280 \times 91.3 \text{ kW} / (6 \times 95)$$

$$P = 45 \text{ kW}$$

Calculation of Drive Torque

$$M = \frac{1.59 \times V \times p}{\eta}$$

M [Nm]

V [cm³/rev]

p [bar]

η [%]

Example: RKP 63 cm³/rev, 280 bar:

V = 63 cm³/rev

p = 280 bar

η = 95%

$$M = 1.59 \times 63 \times 280 \text{ Nm} / 95$$

$$M = 295 \text{ Nm}$$

MODEL CODE

Selection

Standard version: Operating pressure 280 bar (4,000 psi), single pump, clockwise rotation, mineral oil operation standard drive flange, metric, key shaft

Compensator	Displacement cm ³ /rev	Model code	Order number
Pressure compensator, adjustable from 80 to 350 bar (1,160 to 5,000 psi)	19	HPR18A1 RKP019SM28F2Z00	D951-2079-10
	32	HPR18A1 RKP032KM28F2Z00	D952-2007-10
	45	HPR18A1 RKP045KM28F2Z00	D953-2015-10
	63	HPR18A1 RKP063KM28F2Z00	D954-2003-10
	80	HPR18A1 RKP080KM28F2Z00	D955-2003-10
	100	HPR18A1 RKP100TM28F2Z00	D956-2003-10
	140	HPR18A7 RKP140TM28F2Z00	D957-2075-10
Pressure compensator, hydraulically controlled	19	HPR18A1 RKP019SM28H1Z00	D951-2009-10
	32	HPR18A1 RKP032KM28H1Z00	D952-2009-10
	45	HPR18A1 RKP045KM28H1Z00	D953-2017-10
	63	HPR18A1 RKP063KM28H1Z00	D954-2013-10
	80	HPR18A1 RKP080KM28H1Z00	D955-2013-10
	100	HPR18A1 RKP100TM28H1Z00	D956-2011-10
	140	-	-
Combined pressure and flow compensator	19	HPR18A1 RKP019SM28J1Z00	D951-2007-10
	32	HPR18A1 RKP032KM28J1Z00	D952-2001-10
	45	HPR18A1 RKP045KM28J1Z00	D953-2001-10
	63	HPR18A1 RKP063KM28J1Z00	D954-2011-10
	80	HPR18A1 RKP080KM28J1Z00	D955-2017-10
	100	HPR18A1 RKP100TM28J1Z00	D956-2017-10
	140	-	-
RKP-D (digital pQ control)	19	HPR18A1 RKP019SM28D1Z00	D951-2013-10
	32	HPR18A1 RKP032KM28D1Z00	D952-2005-10
	45	HPR18A1 RKP045KM28D1Z00	D953-2059-10
	63	HPR18A1 RKP063KM28D1Z00	D954-2075-10
	80	HPR18A1 RKP080KM28D1Z00	D955-2031-10
	100	HPR18A1 RKP100TM28D1Z00	D956-2039-10
	140	HPR18A7 RKP140TM28D1Z00	D957-2039-10

MODEL CODE

The Model Code Describes Pump Options

There are design interfaces (flange, shaft end and ports), hydraulic parameters (volume flow, operating pressure and hydraulic fluid) and control options.

Examples

Position number	1		2	3	4			
Drive	HP	-	R	18	B1	-		

Position number	5	6	7	8	9	10	11	12
Pump 1	RKP	100	T	M	28	D1	Z	00
Pump 2	RKP	063	K	M	28	D2	Z	00
Pump 3	AZP	008	R	M	28	TP	0	00

	Drive			Radial Piston Pump								
Position	1	2	3	4	5	6	7	8	9	10	11	12
Code	HP	R	18	B1	RKP	100	T	M	28	D1	Z	00
					Radial Piston Pump							
		5	6	7	8	9	10	11	12			
		RKP	063	K	M	28	D2	Z	00			
		Additional Pump Stage										
		5	6	7	8	9	10	11	12			
		AZP	008	R	M	28	TP	0	00			

MODEL CODE

Position	Code	Radial Piston Pump
1	HP HK HZ	Code Hydraulic Pump Explosion protection pump (ATEX) Pump with special features
2	R L	Rotations Clockwise, looking at drive shaft Counterclockwise, looking at drive shaft
3	18	Speed Maximum speed for low noise operation or rated speed for power controlled pumps, e. g. 18 => n = 1,800 min ⁻¹
4	A1 B1 A7 B7 C3 D3 A5 C6 XX	Drive flange Straight key according to DIN 6885, metric round flange (not for RKP 140 and RKP 250) Spline according to DIN 5482, metric round flange (not for RKP 140 and RKP 250) Straight key according to DIN 6885, 4 holes ISO flange according to ISO 3019-2 (metric) Spline according to DIN 5480, 4 holes ISO flange according to ISO 3019-2 (metric) Straight key according to SAE 744 C, 2/4 holes SAE-flange according to ISO 3019-1 (inch) Spline according to SAE 744 C (ISO 3019-1), 2/4 holes SAE-flange according to ISO 3019-1 (inch) Straight key according to DIN 6885, metric round flange for polyurethane foam Straight key according to SAE 744 C, 2/4 holes SAE-flange according to ISO 3019-1 (inch) for polyurethane foam Intermediate flange RKP/RKP
5	RKP AZP DS1	Pump type Radial piston pump, variable displacement Moog gear pump with SAE-A and SAE-B flange Attachment of other pumps Heavy-duty through-drive for RKP attachment and adapter flange for SAE-A, SAE-B or SAE-C
6	019 032 045 063 080 100 140 250 005 008 011 016 019 023 031 033 044 050	Displacement RKP 19 cm ³ /rev 32 cm ³ /rev 45 cm ³ /rev 63 cm ³ /rev 80 cm ³ /rev 100 cm ³ /rev 140 cm ³ /rev 250 cm ³ /rev Displacement and attachment flange of Moog gear pumps (AZP) 5 cm ³ /rev SAE-A 8 cm ³ /rev SAE-A 11 cm ³ /rev SAE-A 16 cm ³ /rev SAE-A 19 cm ³ /rev SAE-A 23 cm ³ /rev SAE-A 31 cm ³ /rev SAE-A 33 cm ³ /rev SAE-B 44 cm ³ /rev SAE-B 50 cm ³ /rev SAE-B
7	K T T S H R	Pump ports Medium pressure series (to 280 bar (4,000 psi)) sizes 32, 45, 63 and 80 cm³/rev Medium pressure series (to 280 bar (4,000 psi)) sizes 100 cm³/rev and 140 cm³/rev High pressure series (to 350 bar (5,000 psi)) sizes 32, 63, 80 and 250 cm ³ /rev Medium pressure series (to 280 bar (4,000 psi)) size 19 cm³/rev High pressure series (to 350 bar (5,000 psi)) size 19 cm ³ /rev German 4 bolt flange (only for gear pumps)

¹⁾ See catalog RKP with digital control (RKP-D)
Options may increase price. Not all combinations may be available.
Note: Preferred configurations are highlighted. Subject to change.

MODEL CODE

Position	Code	Radial Piston Pump
8	M A B C D E	Operating fluid Mineral Oil HFA (oil in water) HFB (oil in water) HFC (water glycol) HFD (synthetic ester) Cutting Emulsion
9	28 35	Operating pressure Maximum operating pressure e.g., 28 => 280 bar (4,000 psi) Maximum operating pressure e.g., 35 => 350 bar (5,000 psi)
10	B1 C1 D1 ¹⁾ D2 ¹⁾ D3 ¹⁾ D4 ¹⁾ D5 ¹⁾ D6 ¹⁾ D7 ¹⁾ D8 ¹⁾ F1 F2 G1 G2 H1 H2 J1 J2 N1 R1 S1 S2 S3 TP	Control/Compensators Mechanical stroke adjustment (V = constant) Servo control RKP-D (electro-hydraulic control with digital on-board electronics), internal pressure supply RKP-D (electro-hydraulic control with digital on-board electronics), external pressure supply RKP-D with external pressure supply, useable for hybrid operation RKP-D with internal pressure supply, useable for hybrid operation RKP-D with internal pressure supply useable for master/slave operation RKP-D with external pressure supply useable for master/slave operation RKP-D with external pressure supply useable for master/slave and hybrid operation RKP-D with internal pressure supply useable for master/slave and hybrid operation For RKP-D with EtherCAT only the options D5, D6, D7, D8 are available Pressure compensator, adjustable from 30 to 105 bar (435 to 1,523 psi) Pressure compensator, adjustable from 80 to 350 bar (1,160 to 5,000 psi) Pressure compensator, adjustable and lockable, from 30 to 105 bar (435 to 1,523 psi) Pressure compensator, adjustable and lockable, from 80 to 350 bar (1,160 to 5,000 psi) Pressure compensator, hydraulically controlled Mooring control Combined pressure and flow compensator $\Delta p = 10$ bar (145 psi) Combined pressure and flow compensator $\Delta p = 20$ bar (290 psi) Dual-displacement Combined pressure and flow compensator with P-T control notch Constant horsepower control Constant horsepower control with pressure-flow limitation, $\Delta p = 10$ bar (145 psi) Constant horsepower control with pressure-flow limitation, $\Delta p = 20$ bar (290 psi) Gear pump
11	Z Y 0	Additional equipment No Accessories Maximum flow limiter Only at gear pump
12	00 01 A0 04 05 07 11 15 18 22 30 37 45 55 75 05 to 50	Additional information For Compensators D1 to D8 CAN bus, actual value output 4 to 20 mA CAN bus, actual value output 2 to 10 V EtherCAT bus, actual value output 4 to 20 mA For compensators S1, S2, S3 power consumption for speed 1,450 or 1,750 min⁻¹ (other speed upon request) 4 kW (RKP 32) 5.5 kW (RKP 32, 45) 7.5 kW (RKP 32, 45, 63) 11 kW (RKP 32, 45, 63, 80) 15 kW (RKP 32, 45, 63, 80, 100) 18 kW (RKP 45, 63, 80, 100) 22 kW (RKP 63, 80, 100) 30 kW (RKP 63, 80, 100, 140) 37 kW (RKP 80, 100, 140) 45 kW (RKP 80, 100, 140) 55 kW (RKP 140) 75 kW (RKP 140) For tandem gear pumps: Displacement of the 2nd gear pump 5 to 50 cm ³ /rev

¹⁾ See [catalog](#) RKP with digital control (RKP-D)
Options may increase price. Not all combinations may be available.
Note: Preferred configurations are highlighted. Subject to change.